



Union Special[®]
INDUSTRIAL SEWING EQUIPMENT

STYLES

56400D

56400R

56400S

56400X

**ADJUSTING INSTRUCTIONS AND
ILLUSTRATED PARTS LIST**

**CLASS 56400
ADVANCED HIGH SPEED
TWO NEEDLE
FIFTY THOUSAND SERIES
FLAT BED MACHINES**

**CATALOG NO.
T129D**

FIRST EDITION

Catalog No. T129 D
(Supplement to Catalog No. 129 M)

INSTRUCTIONS
FOR
ADJUSTING AND OPERATING
LIST OF PARTS

CLASS 56400

Styles

56400 D 56400 R
56400 S 56400 X

First Edition

Copyright 1968
by
Union Special Machine Co.
Rights Reserved in All Countries

Union Special
MACHINE COMPANY
INDUSTRIAL SEWING MACHINES
CHICAGO

October, 1968

Printed in U. S. A.

STYLES OF MACHINES IN CLASS 56400

Advanced High Speed Two Needle Flat Bed Machines, Left Needle in Front, Independent Row, Low Throw, Needle Bearing Needle Bar Drive, Light Weight Presser Bar and Needle Bar Driving Mechanism, Single Reservoir Enclosed Positive Automatic Lubricating System, Filtered Oil Return Pumps for Head and Base, Needle Bearings and Bronze Bearings for Feed Bar and Feed Rocker Shafts Greased and Sealed, Lateral Looper Travel, Large Handwheel and Improved Belt Guard, Prepared for use with Knee Press for Foot Lifter, Equipped with Rotary Thread Tensions, Work Space to Right of Needle Bar 8 1/4 Inches.

56400 D For hemming and simultaneously inserting elastic in tops and legs of knitted undergarments and similar operations on light to medium weight materials. To be used with Galkin close-coupled puller. Attachments are not furnished with machine. Seam Spec. 401-EFg-2. Type 106 GS needle. Standard gauges Nos. 12 and 16. Maximum recommended speed 6500 R.P.M.

56400 R For attaching set-on center plaits and interlining strip to shirts and similar operations on light to medium weight materials. Start operation at the neck. Seam Spec. 401-LSm-2. Type 106 GHS needle. Standard gauge No. 48. Maximum recommended speed 6500 R.P.M.

56400 S For folding and attaching inside button facings to fronts of shirts and similar operations on light to medium weight materials. Start operation at the neck. Facing strip guided next to feed dog. Seam Spec. 401-LSk-2. Type 106 GHS needle. Standard gauges Nos. 32 and 48. Maximum recommended speed 6500 R.P.M.

56400 X For quilting collar bands of shirts and similar operations on light to medium weight materials. No. 26 gauge is equipped with a folder so that this machine can also be used for setting sleeves on extra fine quality shirts. Seam Spec. 401-SSa-2 or 401-LSc-2. Type 106 GHS needle. Standard gauges Nos. 24 and 26. Maximum recommended speed 6500 R.P.M.

APPLICATION OF CATALOG

This catalog is a supplement to Catalog No. 129 M and should be used in conjunction therewith. Only the parts found on Styles 56400 D, R, S and X, but not on Style 56400 P are illustrated. At the back are illustrations identifying the parts by reference number and on the following pages the part numbers and description identifies the part. Any part that is a component of another part is indicated by indenting its description under the description of the assembly or base part. Always use the part number in the second column, never use the reference number in the first column when ordering repair parts.

IDENTIFYING PARTS

Where construction permits, each Union Special part is stamped with its catalog part number. A part too small for its complete catalog stamping is identified by a letter symbol which distinguishes it from another part similar in appearance.

Each part number represents the same part, regardless of the catalog in which it appears.

IMPORTANT! ON ALL ORDERS, PLEASE INCLUDE PART NUMBER AND STYLE OF MACHINE FOR WHICH PART IS ORDERED.

TERMS

Prices are strictly net cash and are subject to change without notice. All shipments are forwarded f.o.b. shipping point. Parcel Post shipments are insured unless otherwise directed. A charge is made to cover the postage and insurance.

NEEDLES

Needle Type 106 GS is recommended for Style 56400 D, and needle Type 106 GHS is recommended for Styles 56400 R, S and X. The descriptions and sizes available are as follows:

- 106 GS Round shank, round point, extra short, double groove, struck groove, ball eye, chromium plated and is available in sizes 027, 029, 032, 036, 040, 044, 049.
- 106 GHS Round shank, round point, extra short, double groove, struck groove, ball eye, ball point, chromium plated and is available in sizes 032, 036, 040, 044.

ASSEMBLING AND ADJUSTING SEWING PARTS

All of the adjusting instructions for Style 56400 P are applicable for Styles 56400 D, R, S and X except as follows:

On Style 56400 D use Type 106 GS needle in place of Type 106 GHS needle.

On Style 56400R set Tru-Front folder as low and as close to the presser foot as possible, so that there is only enough space between it and the throat plate to permit free passage of the body material, keeping the margins equal. Set body folder 1/16 inch to the left of the left needle. Use 2 1/4 inch wide center plait strips, finishes 1 1/4 inches wide and 1 7/32 inch wide interlining strips for plait folder. Material must pass through folders freely to prevent scuffing by the feed dog. Test plate No. 698 AP-48 is available for aligning the needle bar. Use PI40 A test pins.

On Style 56400S set the facing strip folder delivery end flush with the top of the throat plate and with equal margins. Set the body folder so the material projects slightly beyond the facing. Use 1 inch wide strips finishing 5/8 inch wide on No. 32 gauge and 1 1/4 inch wide strips finishing 7/8 inch wide on No. 48 gauge. Material must pass through the folder freely to prevent scuffing by the feed dog. Test plate No. 698 AP-32 for 32 gauge and test plate No. 698 AP-48 for 48 gauge are available for aligning the needle bar. Use PI40 A test pins.

On Style 56400 X set the edge guide to within 1/32 inch of the right side of the presser foot bottom. Set the folder as close as possible to the presser foot with the right edge of the material 1/32 inch from the needle. Material must pass through the folder freely to prevent scuffing by the feed dog. Test plate No. 698 AP-24 for 24 gauge and test plate No. 698 AP-26 for 26 gauge are available for aligning the needle bar. Use PI40 A test pins.

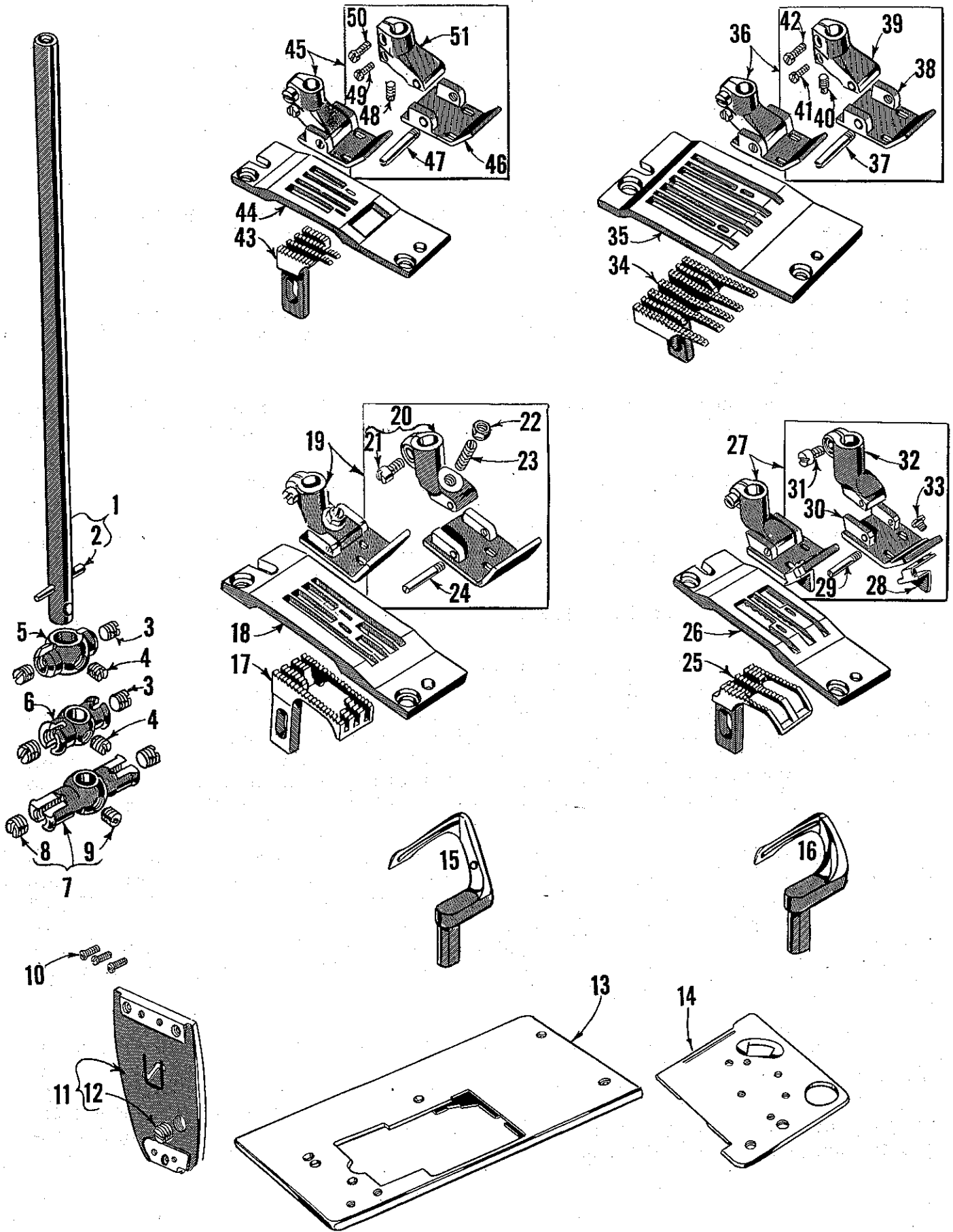

The parts illustrated on the preceding page and on page 4, and described below and on page 5 represent the parts that are used on Styles 56400 D, R, S and X, but are not used on Style 56400 P. The parts are used on all styles unless otherwise specified.

Use Catalog No. 129 M (Style 56400 P) for all parts not illustrated or described in this catalog.

Reference numbers that are inside a bracket or box on the picture plate and have indented descriptions indicate they are component parts of a complete part or assembly.

Ref. No.	Part No.	Description	Amt. Req.
1	51417 D	Needle Bar, marked "DE", for Nos. 24, 26, 32 and 48 gauges, Styles 56400 R, S, X -----	1
2	50 J-40	Stop Pin -----	1
3	98	Set Screw -----	2
4	89	Spot Screw -----	1
5	51418 K-24	Needle Holder, marked "L-24", for No. 24 gauge, Style 56400 X -----	1
6	51418 K-26	Needle Holder, marked "L-26", for No. 26 gauge, Style 56400 X -----	1
7	51418 B-32	Needle Holder, marked "D-32", for No. 32 gauge, Style 56400 S -----	1
8	51418 D-48	Needle Holder, marked "AC-48", for No. 48 gauge, Styles 56400 R, S --	1
9	98	Set Screw -----	2
10	22894 P	Spot Screw -----	1
11	22569 C	Screw, for head cover, Style 56400 R -----	3
12	56782	Head Cover, for Style 56400 R -----	1
13	22733 C	Plug Screw -----	1
14	56701	Cloth Plate, for No. 48 gauge, Styles 56400 R, S -----	1
15	56381-187	Cloth Plate Cover, for No. 48 gauge, Styles 56400 R, S -----	1
16	51409 B	Looper, back, for Styles 56400 R, S -----	1
17	51408-24	Looper, front, for No. 24 gauge, Style 56400 X -----	1
18	51408-26	Looper, front, for No. 26 gauge, Style 56400 X -----	1
19	51408-32	Looper, front, for No. 32 gauge, Style 56400 S -----	1
20	51408-48	Looper, front, for No. 48 gauge, Styles 56400 R, S -----	1
21	51405 AD-12	Feed Dog, for No. 12 gauge, Style 56400 D -----	1
22	51405 AD-16	Feed Dog, for No. 16 gauge, Style 56400 D -----	1
23	51424 AD-12	Throat Plate, for No. 12 gauge, Style 56400 D -----	1
24	51424 AD-16	Throat Plate, for No. 16 gauge, Style 56400 D -----	1
25	51420 AD-12	Presser Foot, for No. 12 gauge, Style 56400 D -----	1
26	7420 AG-4 1/2	Presser Foot, for No. 16 gauge, Style 56400 D -----	1
27	51430 D	Presser Foot Shank -----	1
28	91	Clamp Screw -----	1
29	51430 F	Adjusting Nut -----	1
30	22840 A	Adjusting Screw -----	1
31	22799 E	Hinge Screw -----	1
32	51405 K-26	Feed Dog, for Nos. 24 and 26 gauge, Style 56400 X -----	1
33	51424 K-24	Throat Plate, for No. 24 gauge, Style 56400 X -----	1
34	51424 K-26	Throat Plate, for No. 26 gauge, Style 56400 X -----	1
35	51420 K-24	Presser Foot, for No. 24 gauge, Style 56400 X -----	1
36	51420 K-26	Presser Foot, for No. 26 gauge, Style 56400 X -----	1
37	53530 E	Guide -----	1
38	22799 B	Hinge Screw -----	1
39	51430 K-24	Presser Foot Bottom, for No. 24 gauge, Style 56400 X -----	1
40	51430 K-26	Presser Foot Bottom, for No. 26 gauge, Style 56400 X -----	1
41	91	Clamp Screw -----	1
42	51430 B	Presser Foot Shank -----	1
43	187 A	Screw, for guide -----	1
44	51405 C-48	Feed Dog, for No. 48 gauge, Style 56400 R -----	1
45	51424 C-48	Throat Plate, for No. 48 gauge, Style 56400 R -----	1
46	51420 C-48	Presser Foot, for No. 48 gauge, Styles 56400 R, S -----	1
47	22799 D	Hinge Screw -----	1
48	51430 C-48	Presser Foot Bottom -----	1
49	51430	Presser Foot Shank -----	1
50	22752 B	Adjusting Screw -----	1
51	77	Clamp Screw, lower -----	1
52	91	Clamp Screw, upper -----	1
53	51405 B-32	Feed Dog, for No. 32 gauge, Style 56400 S -----	1
54	51405 B-48	Feed Dog, for No. 48 gauge, Style 56400 S -----	1
55	51424 B-32	Throat Plate, for No. 32 gauge, Style 56400 S -----	1
56	51424 B-48	Throat Plate, for No. 48 gauge, Style 56400 S -----	1
57	51420 C-32	Presser Foot, for No. 32 gauge, Style 56400 S -----	1
58	51420 C-48	Presser Foot, for No. 48 gauge, Styles 56400 R, S -----	1
59	51430 C-32	Presser Foot Bottom, for No. 32 gauge, Style 56400 S -----	1
60	51430 C-48	Presser Foot Bottom, for No. 48 gauge, Styles 56400 R, S -----	1
61	22799 D	Hinge Screw -----	1
62	22752 B	Adjusting Screw -----	1
63	77	Clamp Screw, lower -----	1
64	91	Clamp Screw, upper -----	1
65	51430	Presser Foot Shank -----	1

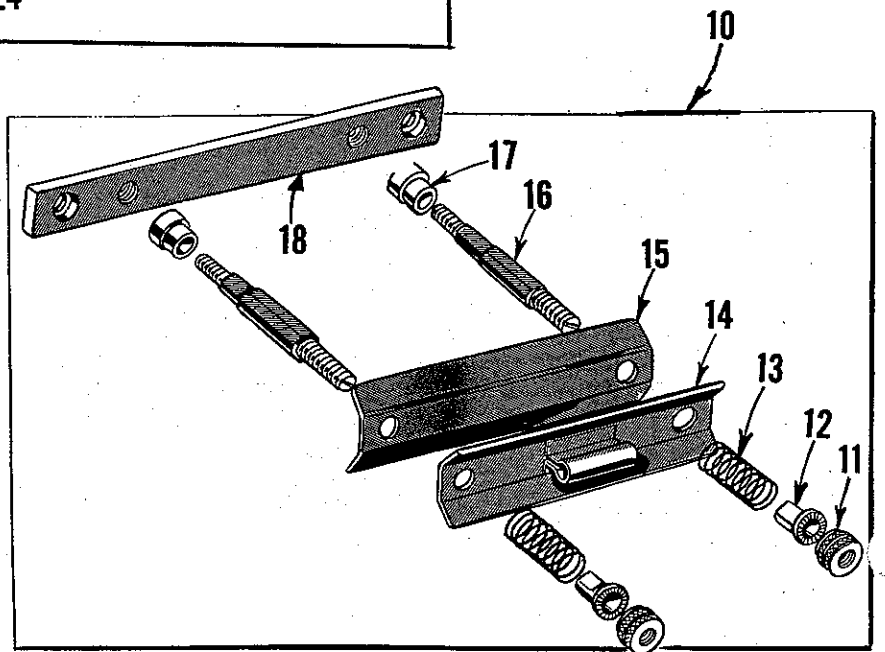
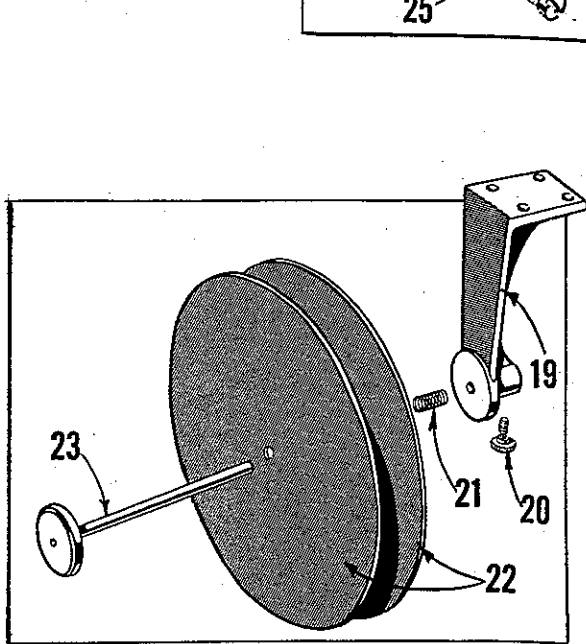
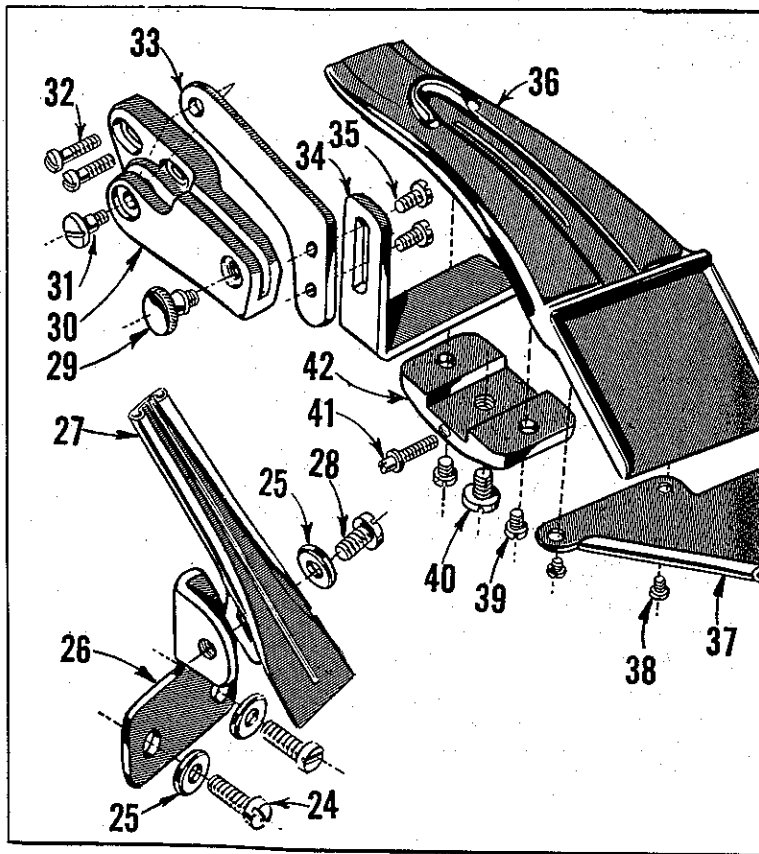
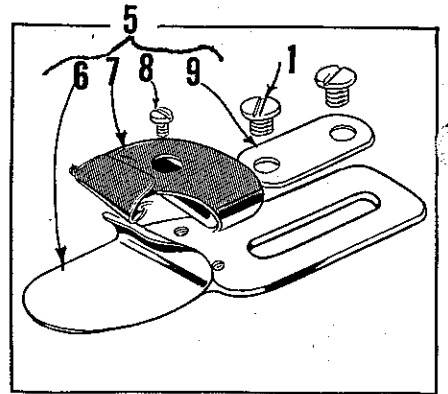
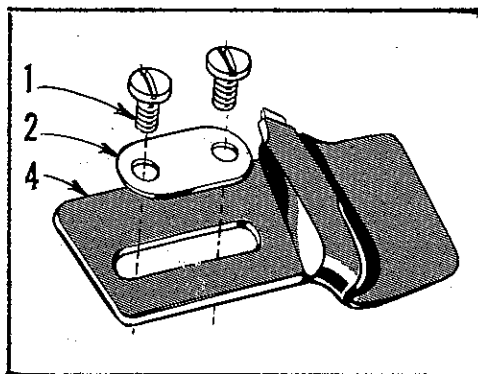
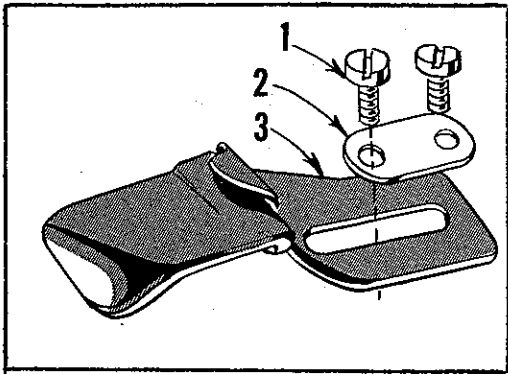

Ref. No.	Part No.	Description	Amt. Req.
1	25 C	Screw, for folder, Styles 56400 R, S, X -----	2
2	23425 V	Washer Plate, for folder, Styles 56400 R, S -----	1
3	23405 J	Folder, for turning body of garment downwardly, 1/32 inch capacity, 5/16 inch fold, for Style 56400 S -----	1
4	23405 L	Folder, for turning body of garment upwardly, 1/32 inch capacity, 5/16 inch fold, for Style 56400 R -----	1
5	23420 U-26-1/16	Double Lap Seam Feller, for No. 26 gauge, Style 56400 X -----	1
6	23422 U-1/16	Lower Scroll and Base -----	1
7	23421 U-26-1/16	Upper Scroll -----	1
8	28	Screw -----	1
9	23425 V	Washer Plate -----	1
10	21182 N	Strip Tension Assembly, for Style 56400 S -----	1
11	108	Tension Nut -----	2
12	107	Tension Spring Ferrule -----	2
13	110-3	Tension Spring -----	2
14	21182 K	Strip Tension Plate, outer -----	1
15	21182 L	Strip Tension Plate, inner -----	1
16	1346	Tension Post -----	2
17	16164	Tension Post Ferrule -----	2
18	21182 P	Strip Tension Base -----	1
19	201 A	Tape Reel Frame, for Styles 56400 R, S -----	1
20	201 C	Tape Reel Axle Screw, for Styles 56400 R, S -----	1
21	110-3	Tape Reel Spring, for Styles 56400 R, S -----	1
22	21178	Tape Reel Disc, for Styles 56400 R, S -----	2
23	21385 B	Tape Reel Axle, for Styles 56400 R, S -----	1
24	136	Screw, for folder bracket, for Style 56400 S -----	2
25	9255	Washer, for folder bracket, for Style 56400 S -----	3
26	23436	Folder Bracket, for Style 56400 S -----	1
27	23435-32	Facing Strip Folder, for shirt front operations, 1/32 inch capacity, uses strip 1 inch wide, finishes 5/8 inch, for No. 32 gauge, Style 56400 S -----	1
	23435-48	Facing Strip Folder, for shirt front operations, 1/32 inch capacity, uses strip 1 1/4 inch wide, finishes 7/8 inch, for No. 48 gauge, Style 56400 S -	1
28	22548	Screw, for facing strip folder, Style 56400 S -----	1
29	25 T	Screw, for folder swinging arm, for Style 56400 R --	1
30	23229 W	Folder Swinging Arm Support, for Style 56400 R ----	1
31	22773	Screw, for folder swinging arm, for Style 56400 R --	1
32	22541	Screw, for folder swinging arm support, for Style 56400 R -----	2
33	23229 N	Folder Swinging Arm, for Style 56400 R -----	1
34	23229 P	Folder Bracket, for Style 56400 R -----	1
35	22528	Screw, for folder bracket, for Style 56400 R -----	2
36	23401 K-48	Center Plait Folder, 1/32 inch capacity, plait extends 1/4 inch beyond rows of stitches, uses plait cut 2 1/4 inches wide, finishes 1 1/4 inches, interlining strip cut 1 7/32 inches wide, for Style 56400 R -----	1
37	23403-48	Angular Strip Guide, reversible, for Style 56400 R -	1
38	25 B	Screw, for angular strip guide, for Style 56400 R ---	2
39	25 CC	Screw, for folder, for Style 56400 R -----	2
40	25 S	Screw, for folder clamp, for Style 56400 R -----	1
41	22863 A	Adjusting Screw, for folder, for Style 56400 R -----	1
42	23229 Q	Folder Clamp, for Style 56400 R -----	1



Union Special
INDUSTRIAL SEWING EQUIPMENT