開頭語

衷心感謝您購買本公司產品！使用縫紉機之前，請認真閱讀此說明書。本說明書介紹了縫紉機日常使用、維護與安全的有關注意事項。請您仔細加以保管，以便日后查閱。如產品規格或外觀經過改良可能會與說明書略有不同，恕不另行通知。

PROLOGUE

Thanking you for your purchase our products sincerely, please reading the manual book before operation, the book introduce some points how to operate, maintenance, and safe. Please keep it carefully for reading in the further; you will be not informed if the file has been revised. Please set sample as standard.



爲了安全

對於縫紉機本身各種裝置，我們充分考慮到它的安全性。請遵照基本的操作方法，安全的進行工作。

- 拆除爲保證安全所設置的裝置，零件的情況下使用，是非常危險的。請絕對不要拆除后使用。
- 縫紉機在使用時，請不要在縫紉機臺板上放置工具及縫紉時不必要的物品。
- 在對縫紉機進行檢修、調節、清掃、穿線、換針等工作時，爲防止發生事故，務必請切斷電源，在確認即使踩下縫紉機踏板，縫紉機也不轉動之后，再進行操作。

注意

使用離合式馬達的情況下，在關掉電源①后因慣性作用會繼續旋轉。這時如不注意踩動縫紉機踏板②時，縫紉機會突然動作，這是很危險的。

請在關掉電源后，仍繼續踩動踏板②，直至縫紉機完全停下來爲止。

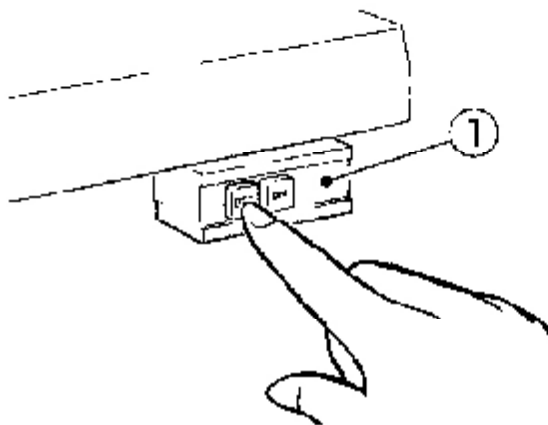

- 在離開縫紉機臺時，務必請關掉電源。
- 停電時也請務必關掉電源。
- 爲了總是安全地，運轉良好的使用縫紉機，日常的點檢是不可缺少的，請予以注意。



OBSERVE THESE SAFETY PRECAUTIONS

Though Our takes the utmost care to produce safe sewing machines and devices, operators should follow these basic safety rules.

- To prevent accidents, do not remove safety devices or parts while operating the machine.
- Do not leave tools or other unnecessary objects on the machine table while operating the machine.
- Before maintenance, adjusting, cleaning, threading or replacing the needle, and to prevent accidents, be sure the power is turned off. Check that the machine will not operate when the pedal is pressed.

Note

In case a clutch type motor is used, it will keep on rotating by inertia after turning off power supply. ① If the machine pedal ② is stepped on inadvertently, it is dangerous because the machine will move unexpectedly. Keep on stepping on the pedal ② until the machine comes to a stop after turning off power supply.

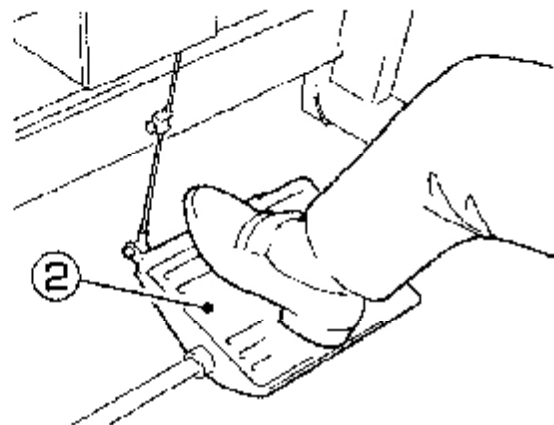

- Turn the power off before leaving the machine table.
- In the event of a power failure, be sure to turn the machine off.
- Check that the machine is securely grounded.

目 录

1. 机器如何安装	1
2. 润滑油之注入与更换	2
3. 针之更换	2
4. 穿线方法	3
5. 控线调整	4
6. 针高度调整	4
7. 护针片调整	5
8. 针与勾线调整	5
9. 勾针调整	5
10. 勾针与拨线杆之关系	6
11. 勾针控线杆之调整	6
12. 针棒上下运动与勾针之时位关系	6
13. 拨线杆之固定	7
14. 送料具调整	7
15. 送料具平行调整	8
16. 缝距之调整	8
17. 后控引轮调整	8
18. 后拉滚轮供给量之调整	9
19. 上下滚轮间隙调整	9

CONTENTS

1. HOW TO SET UP A MACHINE	1
2. LUBRICANT OIL FILLING AND CHANGE	2
3. HOW TO REPLACE NEEDLES	2
4. THREADING	3
5. THREAD TENSION ADJUSTMENT	4
6. NEEDLE POSITION ADJUSTMENT	4
7. NEEDLE GUIDE ADJUSTMENT	5
8. ADJUSTMENT BETWEEN NEEDLES AND LOOPERS	5
9. LOOPER ADJUSTMENT	5
10. INTERRELATION OF LOOPERS AND THREAD WEAVERS	6
11. ADJUSTMENT OF LOOPERS THREAD TAKE-UP	6
12. TIMING OF NEEDLE AND LOOPERS MOVEMENT	6
13. SETTING OF THREAD WEAVERS	7
14. FEED DOG ADJUSTMENT	7
15. FEED DOG'S PARALLEL ADJUSTMENT	8
16. STITCH LENGTH ADJUSTMENT	8
17. REAR PULLER ADJUSTMENT	8
18. FEEDING ADJUSTMENT OF REAR PULLER	9
19. GAP ADJUSTMENT OF TOP AND LOWER ROLLERS	9

1、 機器如何安裝 / HOW TO SET UP MACHINE

1. 依本機器大氣層附桌板裁制圖及零件組合圖所列之配件，依序安裝防震機座，及綫架(圖1&2)。

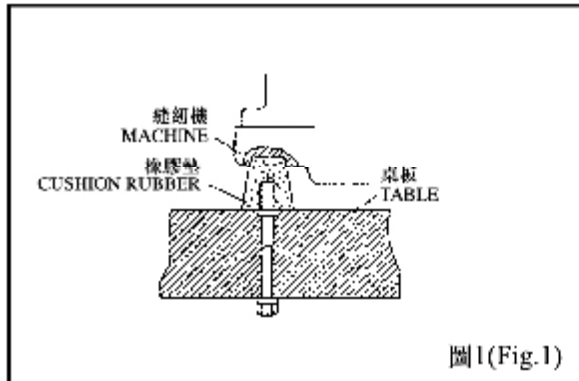

1. With reference to diagrams for table cutting and mounting parts list, install vibration-reducing base and thread stand in sequence (Fig.1&2)

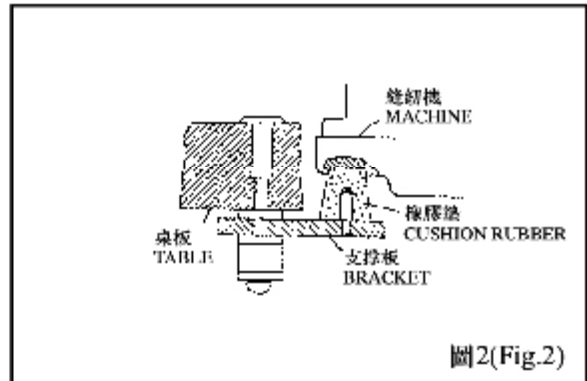

1. 馬達之轉向為順時針方向，皮帶之松緊度以用手指能向內壓20mm為宜，同時為安全起見把皮帶蓋必須鎖上。(圖3&4)

2. Motor should run clockwise, proper tension for driving belt can be checked by pushing belt inward for 20mm, please install belt cover properly and firmly for safety purpose. (Fig. 3&4)

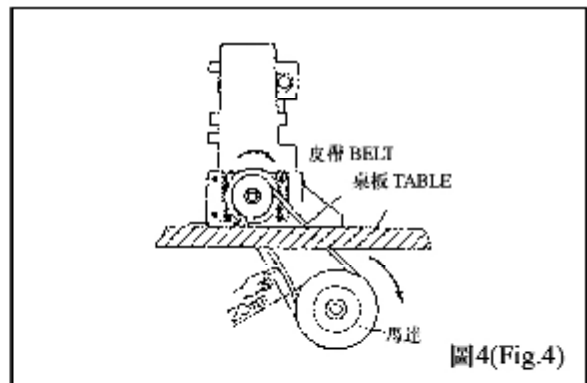
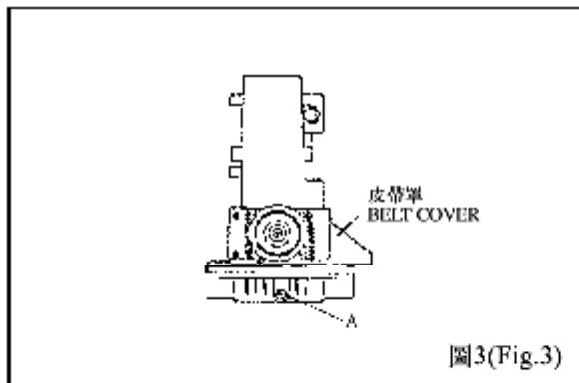

1. 皮帶輪及縫合轉速，請參照(表2)。

3. Motor pulley size and sewing speed, please refer to Table No.2.

注意:

Remarks:

1. 使用新機器最初一個月運轉速度約為最高速度(表2)之80%，并請選擇正確的馬達皮帶輪尺寸(表1)。

1. New machines run a speed at approximately 80% of the Maximum speed in the first month (Tab.1). Be sure to choose proper motor pulley for your machine.

表1 (Table.1)

Machine Speed (s.p.m.) 轉速 / 分	Motor Pulley Outer Diameter (mm)	
	60Hz	50Hz
4,500	90	105
4,000	80	95
3,500	70	85

2. 桌板厚度約50mm。
3. 馬達規格：離合器馬達，3相2極400瓦(1/2HP)。
4. 皮帶規格：M型V字皮帶。

2. Table top is about 50mm thick.
3. Specification of motor: clutch motor 3 phase, 2 poles, 400W (1/2HP)
4. Driving Belt: M type, V belt.

2、潤滑油之注入與更換 / LUBRICANT OIL FILLING AND CHANGE

新機器運裝前均已將油倒盡，因此機器使用前必須加入潤滑油。

New machines are shipped out with empty chambers. please fill lubricant oil into new machines before run them.

1. 潤滑油之注入(圖5&6):

將(A)旋開，以包裝箱內所附之超高速潤滑油或選用MOBLL#10或ESSO#32等極之潤滑油加入，直至油窗(C)內之=油標線間即可，然后在鎖緊(A)。

1. Filling lubricant oil: (Fig.5&6)

* Loosen Knob (A) fill in with accompanied super-high-speed lubricant oil or its equivalent such as Mobil #10 or Esso #32, until the oil is up between two marks on oil Indicator (c)

1. 潤滑油之更換(圖3):

* 將螺絲(A)松開，使油槽之油完全排出后再鎖緊。

* 為延長本機器之壽命，請于開始使用四星期后更換新油，換后約每四個月更換一次。

2. Lubricant oil change: (Fig. 3)

* Loosen knob, (A) drain oil from the tank, then tight it up.

* In order to pro-long machine life, please change lubricant oil after the first 4 week of operation. There after, change oil every 4 months.

1. 濾油器之更換(圖7):

本機器特別裝有濾油器，約每使用一個月后應卸下清洗，必要時得更換新品。

3. Replacing oil filters: (Fig.7)

* Our machines are equipped with oil filters. Take our the filters and clean them up every month. Replace with new filters if necessary.



圖5(Fig.5)



圖6(Fig.6)

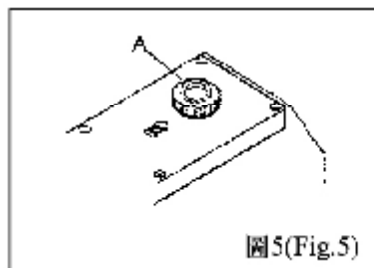

圖7(Fig.7)

3、針之更換 / HOW TO REPLACE NEEDLES

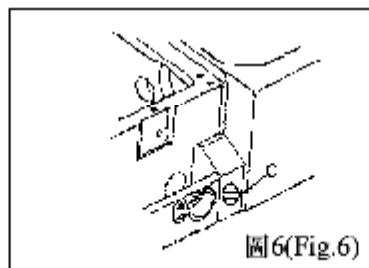
* 選用針之規格與尺寸請參照(表2)

* For specifications and sizes of needles, please refer to (Table. 2).

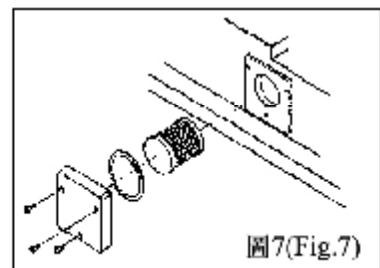
表2 (Table.2)

NEEDLE SYSTEM 針 規 格	NEEDLE SIZE 針 番 號
SCHMETZ UY113GS	#70-#160
OPGAN Uo113	#11-#18

1. 旋動螺絲(A)并取下針。(圖8)
2. 將新針插至含針孔最底端, 并使針之凹弧面向自己。
3. 重新鎖緊螺絲(A)。
4. 四針與勾針有密切之關係, 如果車針穿裝不正確, 不但會引起跳針、斷錢還會損傷勾針, 務必注意。

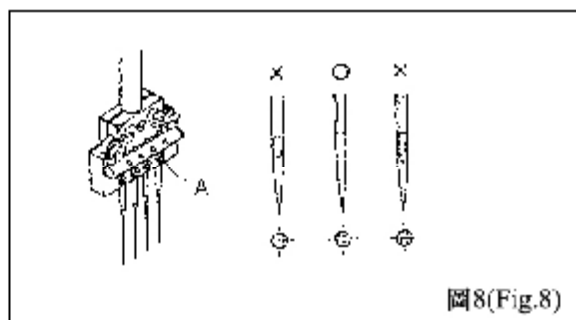

1. Loosen screw (A) and take out the used needle (Fig.8)
2. Put new needle into the holder holes as far as they can go and let the long groove of needle face you.

3. Fasten Screw (A)
4. Needles and loopers have close interaction. improper needle setting will cause skipping stitches, breaking Threads, and damaging loopers, please Pay fing attention to needle installation.

4、穿綫方法 / THREADING

1. 請確認按照圖示穿綫, 錯誤之穿綫將引起內斷綫, 跳針或車縫不平坦等現象(圖9)

1. Please follow threading illustration carefully for proper threading improper threads, skipping stitches, and/or undesired sewings. (Fig. 9)

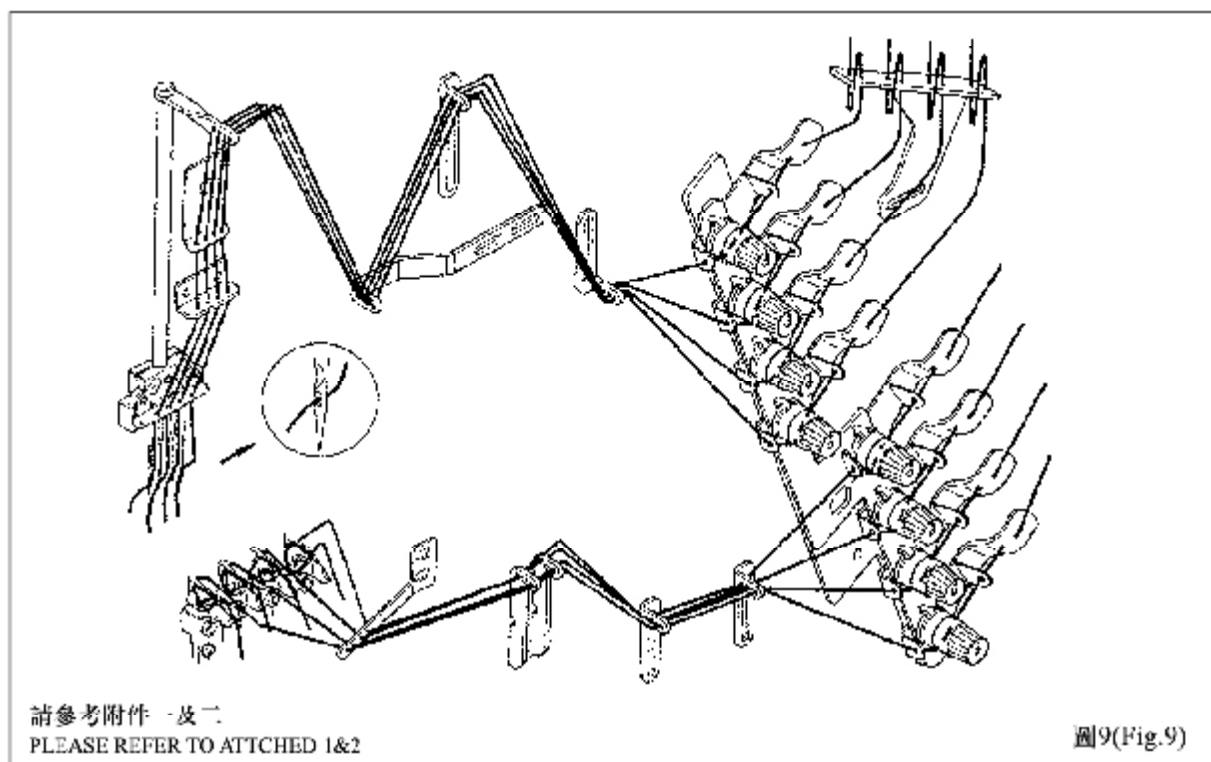

2. 在穿勾針綫時, 應將勾針座引出軸(圖10)沿箭頭方向拉出使勾針座向前彈出, 然後進行穿綫。

2. For looper threading, pull out the lever of looper set as the arron direction then thread properly. (Fig.10)

5、控綫調整 / THREAD TENSION ADJUSTMENT

1. 控綫強弱必須根據車縫材料種類，厚薄及綫與針距等不同而做不同之調整(圖9)。

將控綫鈕順時針旋轉時越緊，反之則越松。

2. 針控綫杆之調整(圖11)針綫控綫杆(B)依縫綫使用種類來選擇使用之狀態，放鬆螺絲(A)將(B)上下移動調整，在使用伸展性大的縫綫時將(B)上移，則針孔處之綫環就會變大，以利勾綫。



圖10(Fig.10)

1. Thread tension, should be adjusted in regarding to kinds of threads fabrics, thickness of fabrics, and stitch length etc..(Fig.9)

Turn thread knob clockwise for tighter tension and vice versa.

2. Adjustment. (Fig.11) The position for Needle thread Take-up Lever (B) is adjustable according to thread used. Loosen screw (A), move lever (B) up and down for the optimum position. For instance, when using high extension thread, move lever (B) upward to make a bigger needle thread loop for lower looper to chain easily.

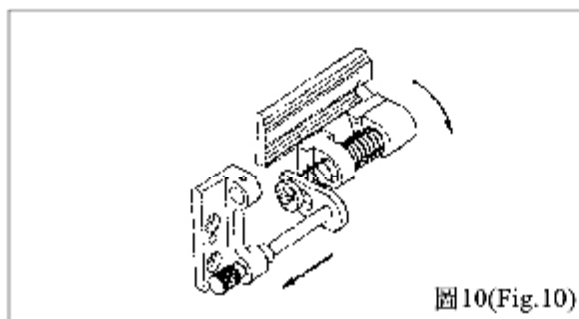

圖11(Fig.11)

6、針高度調整 / NEEDLE POSITION ADJUSTMENT

1. 當針棒升至最高處時，調整針尖與針板面之距離為13-13.5mm(圖12)。

2. 打開上方之側蓋橡膠塞(A)，并松開螺絲(B)，上下調整針棒之高度后再固定之。(圖13)

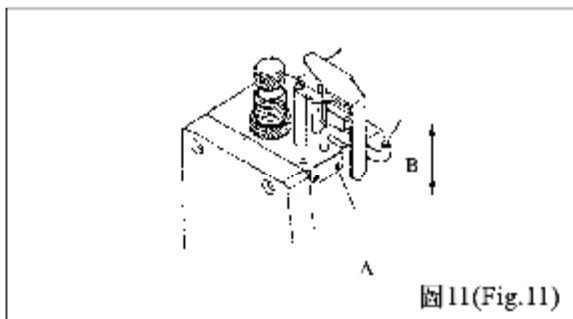
注意：

經過調整后，必須確定每一根針是通過針板的針孔中央，(圖14)。

1. Needle tip should be 13-13.5mm height from Needle plate when Needle Bar mores to its top position. (Fig.12)

2. The position of needle bar can be adjusted by(1) removing rubber cap (A) and loosening nut (B), (2) moving needle bar up and down, to proper position and (3) tightening screw (B), and insert in cap (A). (Fig.13)

REMARK:

Be sur that every needle goes through the center of needle holes on Needle plate. (Fig. 14)



圖12(Fig.12)



圖13(Fig.13)

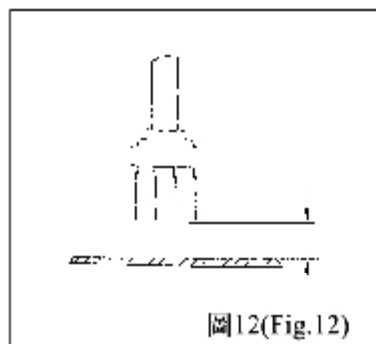

圖14(Fig.14)

7、護針片調整 / NEEDLE GUIDE ADJUSTMENT

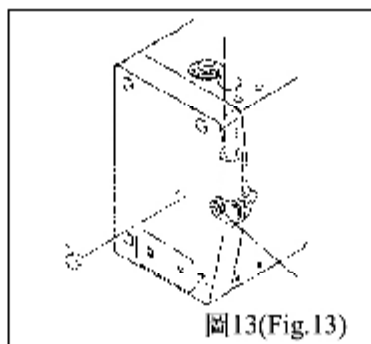
放鬆螺絲(A)，調整護片使與針之間隙為0-0.1mm (圖15)后再鎖緊螺絲(A)。

Loosen screw (A) to allow a gap of 0-0.1mm between needles and Needle Guide (Fig.15) then tighten screw (A)

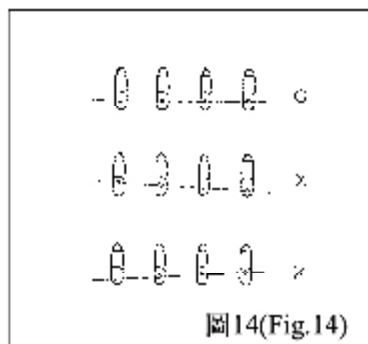
8、針與勾綫之調整 / ADJUSTMENT BETWEEN NEEDLES AND LOOPERS

1. 將勾針完全插入勾針內稍微鎖緊螺絲(A) (圖16)。
2. 轉動皮帶輪使針上升并使勾針尖前時至針之中心綫(圖17)。
3. 調整勾針尖與針側之間隙為0-0.5mm
4. 再鎖緊螺絲(A)。

1. Put Loper into Loper holder with screw (A) slightly tightened. (Fig.16)
2. Turn pulley to move looper point up to the center line of needle. (Fig.17)
3. Adjust the gap between needle tip and looper tip to be 0-0.05mm
4. Tighten screw (A) up.

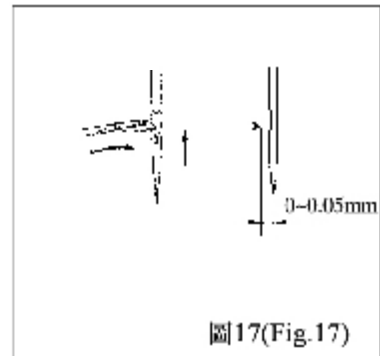
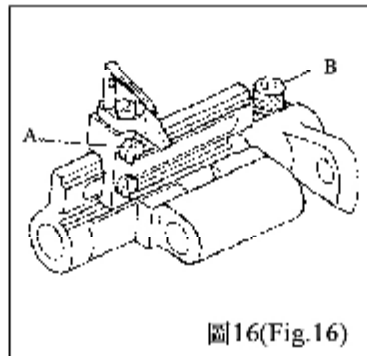
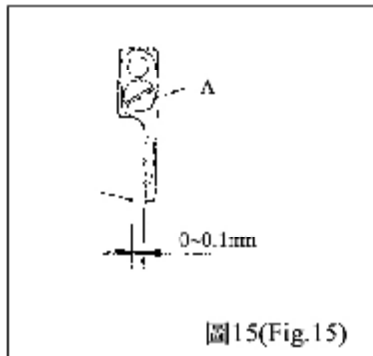

9、勾針調整 / LOOPER ADJUSTMENT

當針位于下死點時，勾針尖端與針中心綫之間隙為2.8mm(圖18)調整時將勾針底座驅動杆固定螺絲(B)放鬆，前后調整勾針座后再鎖緊螺絲(B) (圖16)。

When needles are at the bottom end position, the distance between looper tips and the center line of needles is 2.8mm. (Fig.18) To adjust the position of loopers, first loosen nut (B) on Loper Holder and move back and forth to the proper position. Then tighten nut (B). (Fig.16)

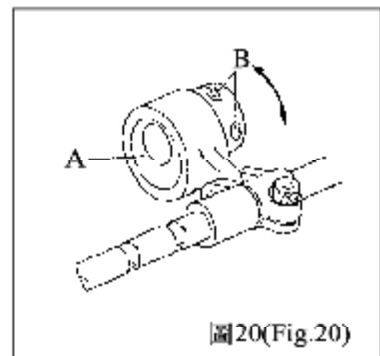
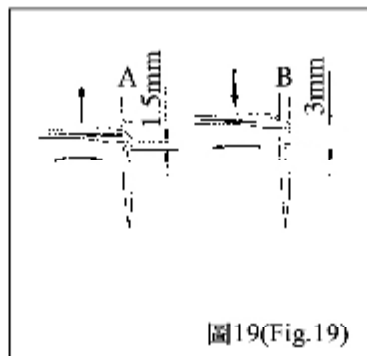
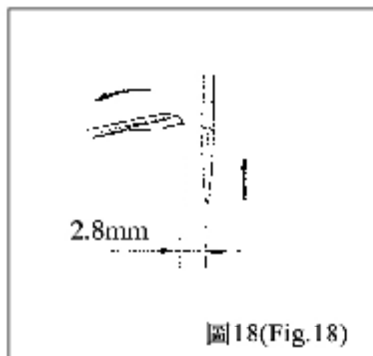

10、勾針與撥綫杆之關係 / INTERRELATION OF LOOPERS AND THREAD WEAVERS

當撥綫杆(A)于左死點位置時，撥綫杆(A)右端與勾針右端二者之間隙為0.5-1mm。(圖22)而勾針與撥綫杆(A)之間隙為0-0.1mm。

調整時:

- 1.先放松再稍鎖緊撥綫杆心軸固定螺絲(C)(圖22),
- 2.旋轉皮帶輪使撥綫杆心軸連杆(D)移至左死點。
- 3.調整使符合上述條件，再鎖緊螺絲(C)。

When thread weavers are at the left dead end position, the right side of thread weavers is away from the right side of loopers by 0.5-1mm (Fig.22). And, the gap between loopers and Thread Weavers is 0-0.1mm (Fig.23).

For adjustment:

1. Loosen but slightly screw (C) on the shaft of thread weavers (Fig.22).
2. Turn belt pulley to move the lever of thread weavers (D) to the left dead end.
3. Adjust loops and thread weavers to meet all requirements mentioned above then tighten screw (C).

11、勾針綫控綫之調整 / ADJUSTMENT OF LOOPER THREAD TAKE-UP

當針尖下降至勾針背面的中心位置時，勾針綫控綫杆(A)也正好由下死點開始要往上抬起。

調整時:(圖24)

1. 放松偏心凸輪(F)固定螺絲(C)前后調整至正確位置，再鎖緊螺絲(C)，往前轉變快，往后轉變慢。
2. 微調整時，放松螺絲(E)，將綫導片(B)上下移動調整再鎖緊螺絲(E)。綫的出綫量因所使用的綫而异，其出綫量為:

棉綫，SP綫：7-10mm (D) (圖25).

伸縮尼龍綫：10-15mm (D) (圖25).

When the needles tip were moved down to the position of the center of loopers' back, the looper thread take-up lever (A) starts to move upward from its bottom dead end.

For adjustment (Fig.24)

1. Loosen screw (C) to release eccentric cam (F) and move eccentric cam to a proper position, by turning forward for faster and backward for slower take-up motion. Then, tighten screw (C).
2. For micro-adjustment: Loosen screw (E) and move Thread Guide (B) up and/or down to the proper position then tighten screw (E). The quantity of thread fed varies with the kinds of thread.

For reference:

Cotton & sp headtr: 7-10mm(D) (Fig.25)

Nylon thread: 10-15mm (D) (Fig.25)

12、針棒上下運動與勾針之時位關係 / TIMING OF NEEDLE AND LOOPERS MOVEMENT

針棒由下死點開始往上移，且勾針尖由后死點往前移至針之右邊緣如(圖19)(A)所示之位置時，勾針尖由前死點往后移至針之右邊緣如(圖19)(B)所示之位置時，勾針即為正確之關係位置。

調整時將勾針前后帶動之偏心凸輪(A)(圖20)之固定螺絲(B)放松，前后調整偏心凸輪(A)之位置，向前移則針對勾針之時間較快，向后移則較慢。

While needles move up from bottom end position and loopers also move forward from rear end position until looper point reach the right side edge of needle (Fig.19) (A), the looper point should be 1.5mm away from the top edge of needle eye.

While needles move down from top end position and loopers also move backward to front end position until same location as above shown on fig.19 (B). Looper point should be 3.0mm away from the top edge of needle eye. For adjustment by loosening screws (B) and move the position of Eccentric Cam (A) (Fig.20) back and forth, the speeds of needles and loopers' movement can be adjusted slower or faster coordinately.

13、撥綫杆之固定 / SETTING OF THREAD WEAVERS

撥綫杆(A)與車針之間隙如(圖21)所示為0.2-0.4mm。當針棒于下死點位置時,將固定螺絲(B)(圖22)放鬆,并調整撥綫杆(A)至(圖21)所示之尺寸并注意各杆之平行。再鎖緊。

The gap between thread weavers and needles is (Fig.21), about 0.2-0.4mm. Move needle bar to its low bottom end position then loosen screws (B) (Fig.22) and move thread weaver to position shown in (Fig.21;) then tight screw (B). Be sure all Thread Weavers are paralleled when tightening screw (B).



圖21(Fig.21)



圖22(Fig.22)

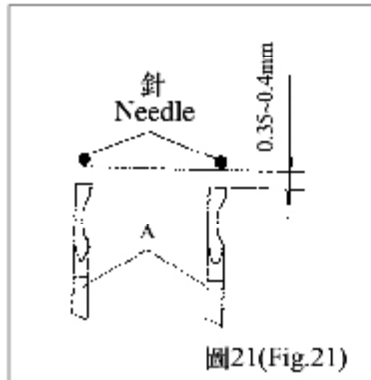

圖23(Fig.23)

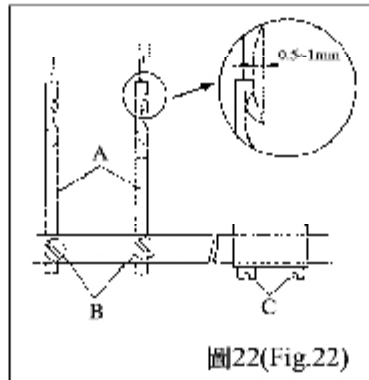

圖24(Fig.24)

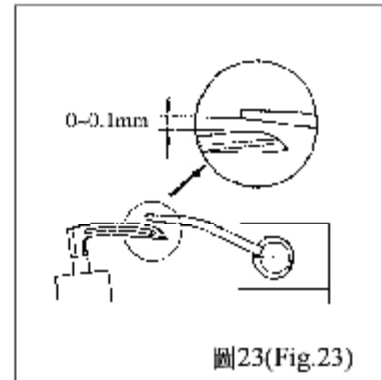

圖25(Fig.25)

14、送料具調整 / FEED DOG ADJUSTMENT

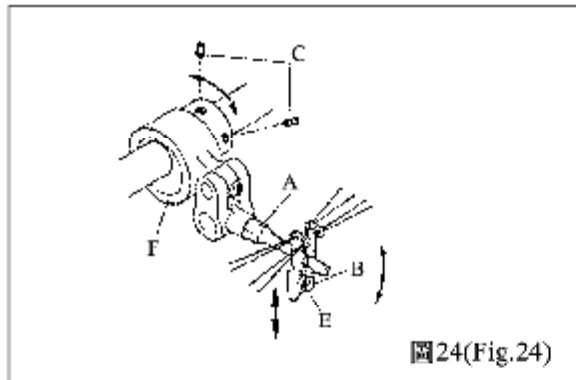
送料具(C)升至最高點時,送料具齒尖而與針板面之距離為0.8-1.5mm,平均為1.2mm。(圖26)

When feed dogs (C) move to the highest position, the distance from the tips of feed dogs to the face of Needle plate is 0.8-1.5mm. The average is 1.2mm. (Fig.26)

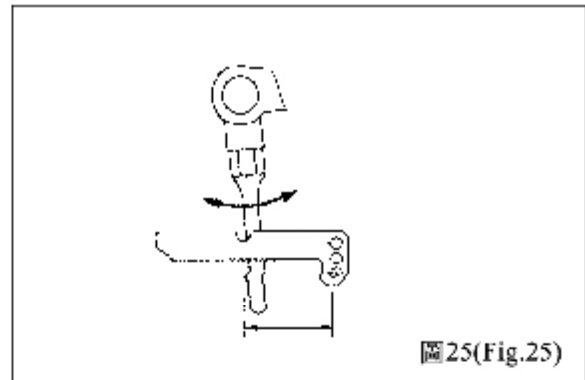
調整時:(圖27)

For adjustment: (Fig.27)

1. 放鬆送料具(C)固定螺絲(A)。
2. 上下移動送料具(C)使符合上述條件時,再鎖緊螺絲(A)。
3. 將高度固定削(D)之固定螺絲(B)放鬆,調整固定削直至送料具(C)底部再鎖緊螺絲(B)(圖27)
4. 此時亦應確認送料具(C)左右方向的平行。

1. Loosen screw (A) on Feed Dog (C)
2. Move Feed Dog (C) up and/or down to meet above requirement then tighten screw (A)
3. Loosen screw (B) and move stop pin (D) upward to the bottom of Feed Dog (E), then tighten screw (B),(Fig.27)
4. Be sure to check the parallel among feed dogs.



圖26(Fig.26)



圖27(Fig.27)

15、送料具平行調整 / FEED DOG'S PARALLEL ADJUSTMENT

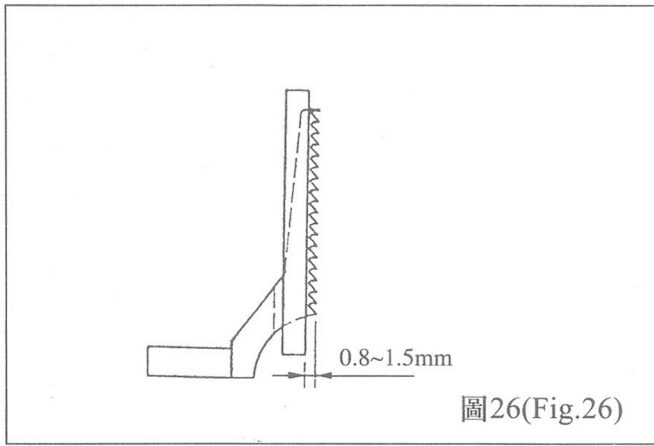
送料具上升至最高時應安裝與針板平行。
(圖26)

調整時：

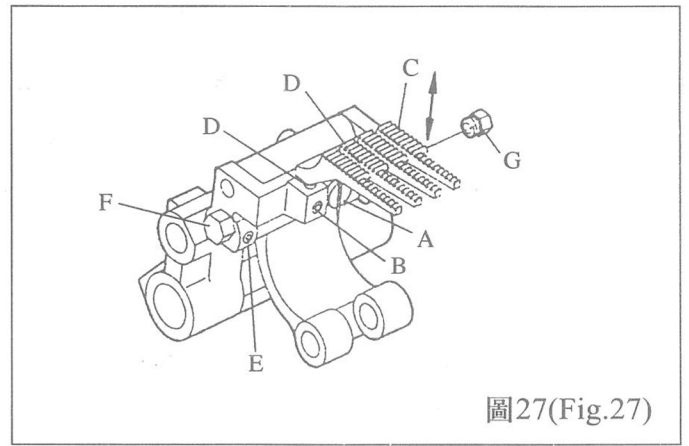
夾緊時螺栓(F)，將螺帽(G)放鬆，調整送料具螺絲(E)，使送料具(C)與針板面平行(圖27)再鎖緊螺帽(G)。

When the feed dogs are at the highest position they should be parallel to Needle plate surface (Fig.26)

For adjustment:

Holding screw nut (F) firmly and loosen screw (G) then to adjust screw (E) for the teeth surface of Feed Dogs, is paralleled needle plate. (Fig.27). Then, tighten screw (G).

16、縫距之調整 / STITCH LENGTH ADJUSTMENT

壓下縫距調整按鈕(A)，并轉動皮帶輪，使按鈕卡住針距調整組，再轉動皮帶輪至所需之縫距后，放鬆此按鈕。(圖28)

欲調長縫距時，將皮帶輪往順時針方向旋轉，反之則小。調整縫距時，馬達需在停止狀態。

Push stitch length regulator button (A) and turn pulley until the button lock in the stitch regulator. Then, turn pulley again to reach desired stitch length. then, release the button. (Fig.28)

Turn pulley clockwise for longer stitch length, vice versa. Be sure to turn off motor when adjusting.



圖28(Fig.28)

17、后控引輪調整 / REAR PULLER ADJUSTMENT

當針棒由下死點往上移24mm，后拉引輪開始轉動，即為正確之時位關係。

調整時：(圖29)

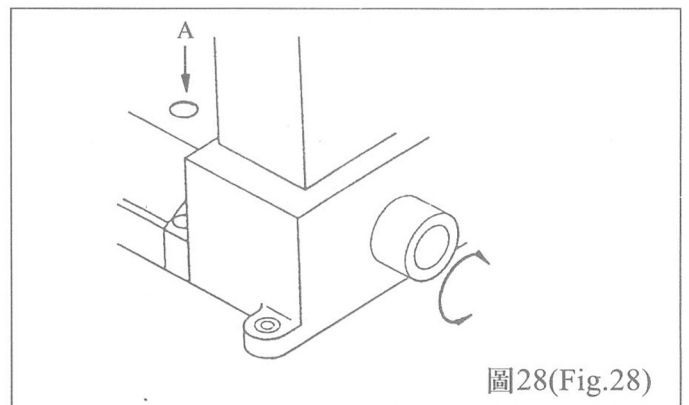
1. 放鬆偏心凸輪(B)固定螺絲(A)后，再稍鎖緊。

When needle bar moves upward from its dead bottom end about 24mm, the rear pulley cam starts moving.

To adjust: (Fig.29)

1. Loosen screws (A) on eccentric cam (B) then tighten them a little bit.

2. 旋轉皮帶輪至上述條件下后，再鎖緊螺絲(A)，往前轉時間變快，往后轉則變慢。

2. Turn pulley to have Needle Bar and rear puller reach their proper tinerelat-ed position. Then tighten screws (A). Turn eccentric cam forward to have faster motion. Vice ver' sa.

18、后拉滾輪供給量之調整 / FEEDING ADJUSTMENT OF REAR PULLER

1. 取下上蓋。
2. 放松連杆(A)上之螺帽(B)。
3. 將連杆(A)前后移動，往前移動(C方向)則供給量小，往后移(D方向)則供給量大。
4. 微量調整時，放松螺帽(A)將連杆(B)上下移動，往上量多。(圖31)

1. Take off top cover.
2. Release nut (B) on connector (A), (Fig.30).
3. Move connector (A) back and forth for more or less feeding length, toward c dilection reduce feeding length.
4. For micro adjustment, release nut (A) and move connector (B) upward for longer and downward for shorter feeding length respectively. (Fig.31)

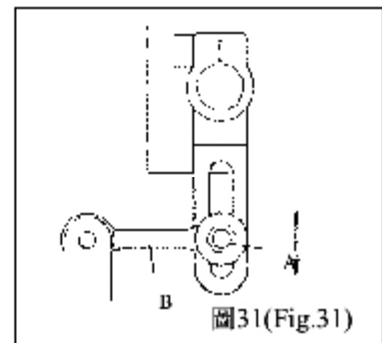
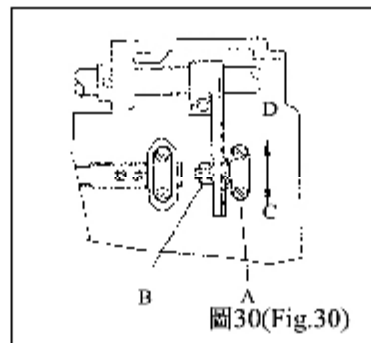
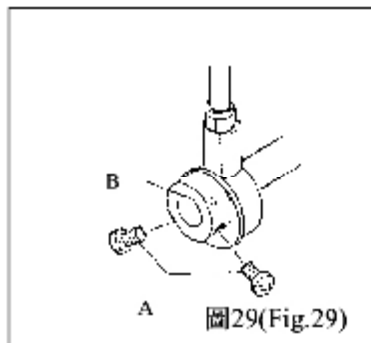

19、上下滾輪間隙調整 / GAP ADJUSTMENT OF TOP AND LOWER ROLLERS

上下滾輪之間隙：將下滾輪放至下死點在自由狀態時，上滾輪與下滾輪之齒間隙為0.5mm(圖32)，且兩滾輪平行。

調整時：

1. 兩滾輪平行之調整

將螺絲(A)放松，調整兩滾輪平行后，稍鎖緊螺絲(A)上下移動固定座(C)，使上下滑動順暢，再鎖緊螺絲(A)。(圖32)

The feeth gap betwen top and lower rollers should be 0.5mm (Fig.32), when the lower roller is free and at its dead bottom end and parallel to the top roller. (Fig.32)

To adjust:

1. Paralleling Loosen screw (A), and put top and lower rollers parallel. Tighten screw (A) slightly and move frame Base (C) up and down to its smoth. Then tighten screw (A) (Fig.32).

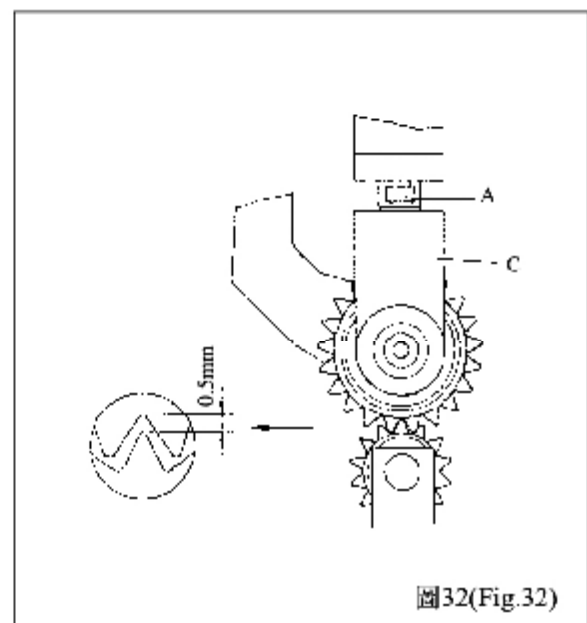

2. 間隙0.5mm之調整:

如(圖33)所示, 將螺帽(D)放松, 調整螺絲(H), 使上下滾輪之間隙為0.5mm再鎖緊螺帽(D) (圖33)稍放松螺絲(K)并調整連杆(J), 使螺絲(L)與連杆(J)之長圓孔下方間隙為0.5mm, 再鎖緊螺絲(K).

2. Gap referring (Fig.33).

Loosen nut (D) and turn screw (H) to reach 0.5 mm gap between top and lower rollers. Then tighten screw nut (D). (Fig.33) release screws (K) slightly and adjust connector (J) to keep the space between the bottom edge of screw (L) and the edge of slot on connector (J) at 0.5mm. Then tighten screws (K).

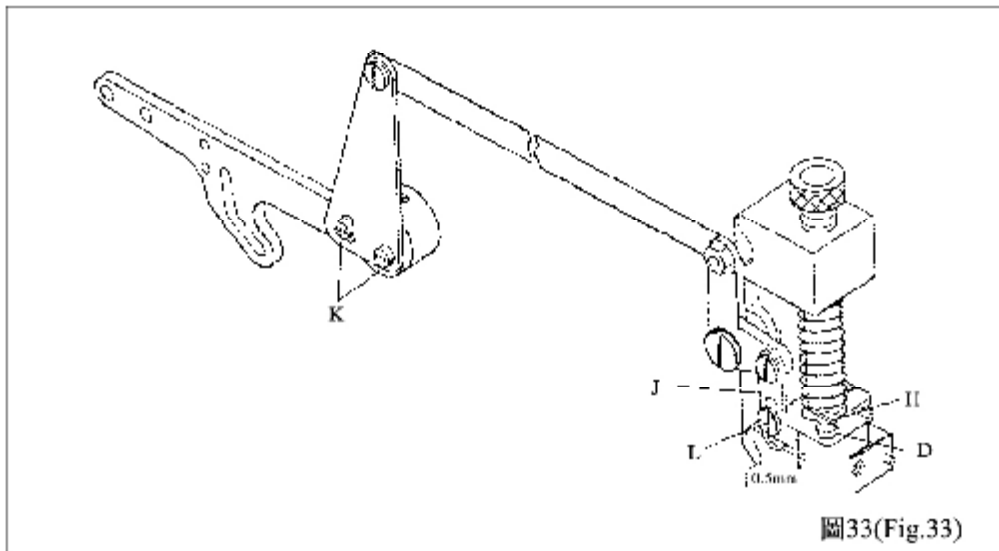

2. 上滾輪壓力之調整

將壓力調整螺絲(A)往順時針方向轉動, 則壓力加大, 反之則減小。(圖34)

3. Pressure

Turn pressure control knob (A) colockwise to increase the pressure of top roller, vice ver'sa. (Fig.34)

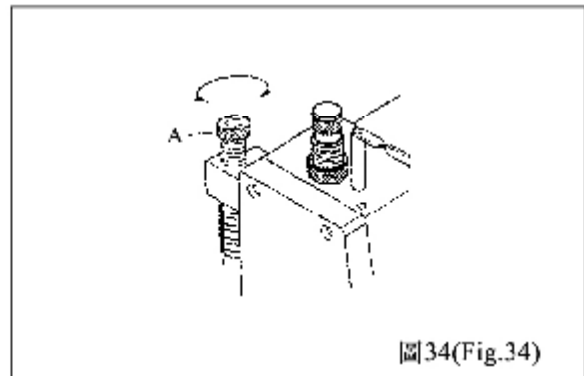

ATTACHMENT 1: JK-8008VC

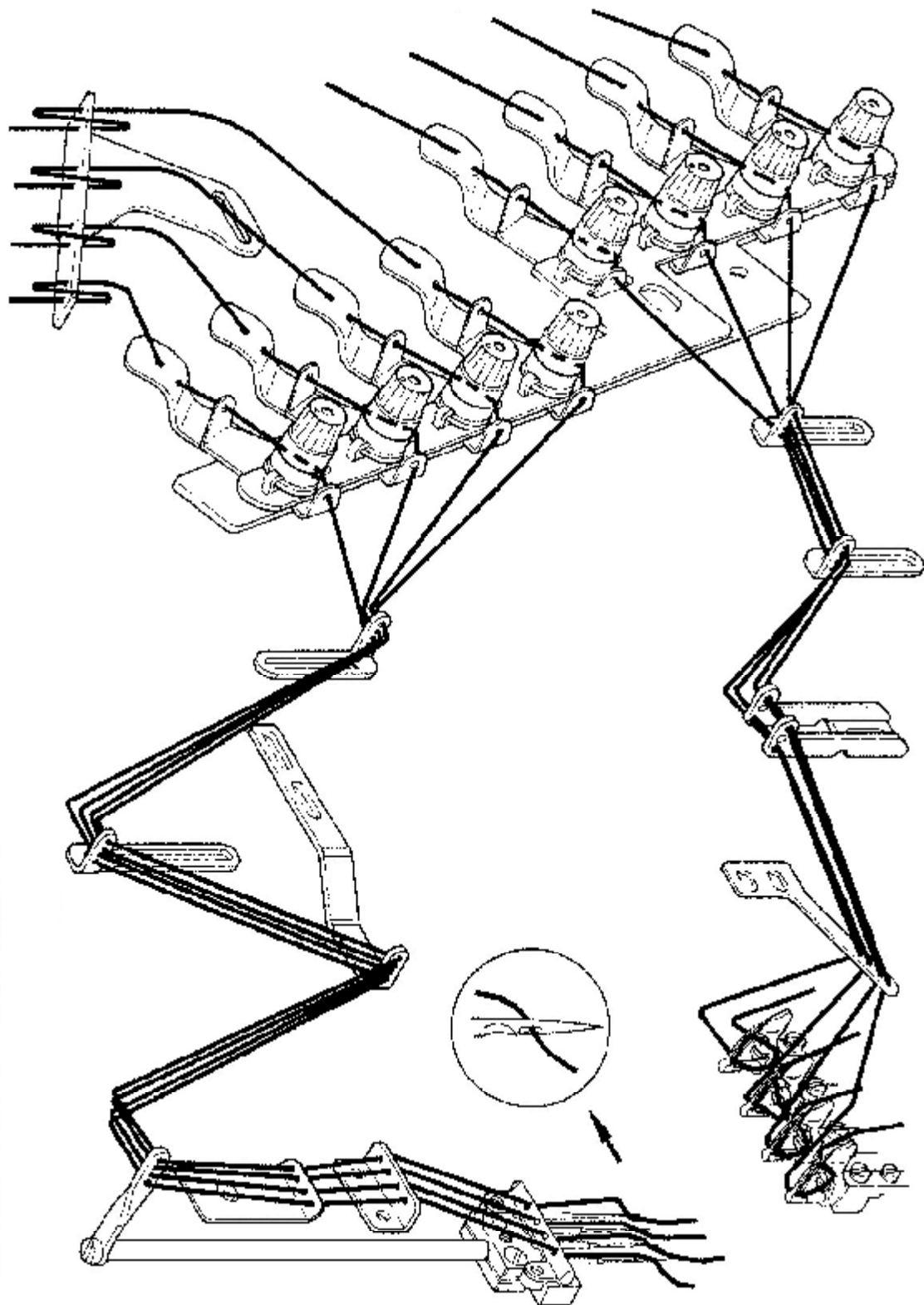

零件样本

PARTS BOOK

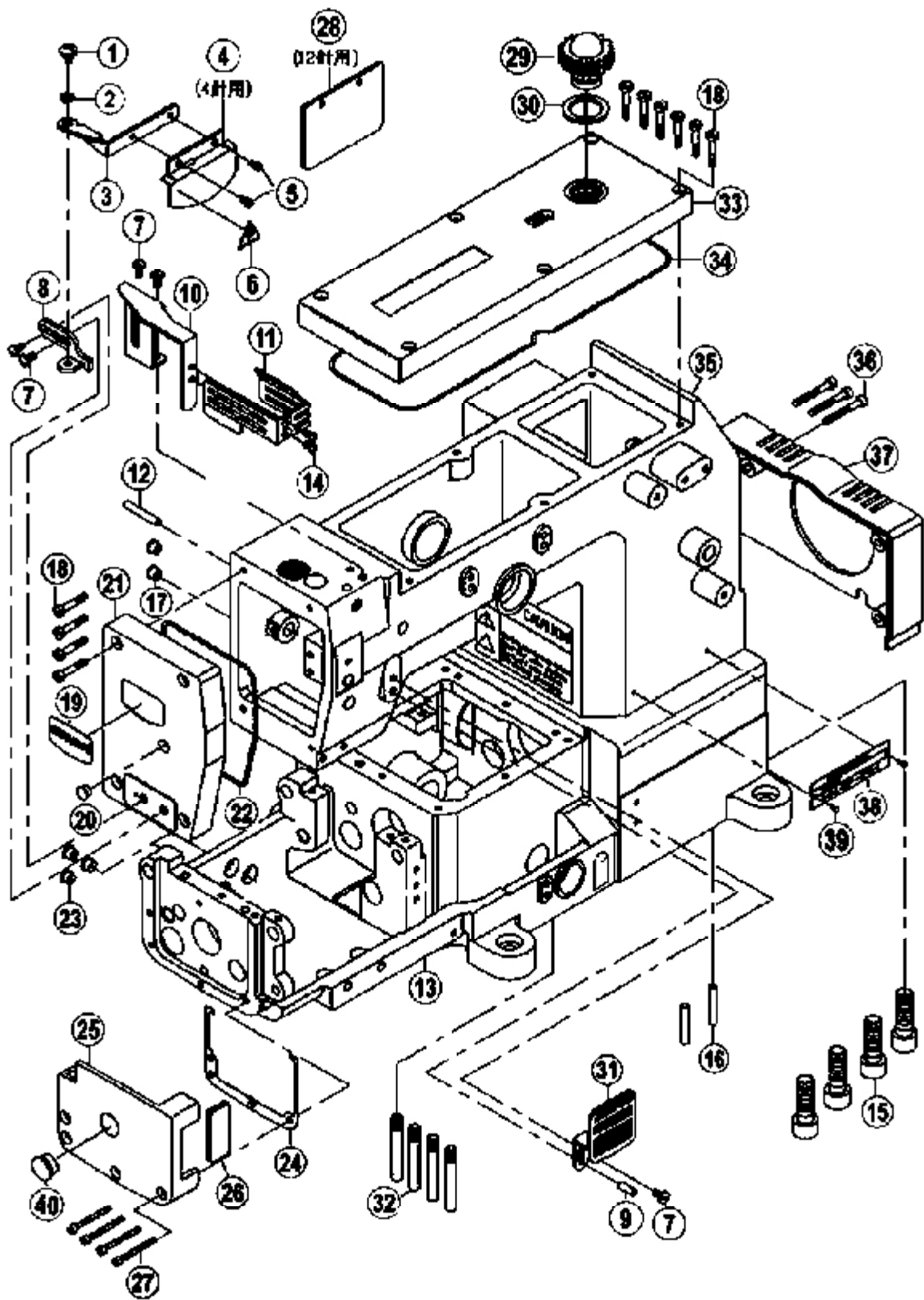

一、機殼部件 / Franc assemblies

序號 NO.	件號 Part NO.	參考件號 Ref.Part.NO.	名 稱	Description	數 量 (Number)				
					4針64	6針64	8針64	12針64	13針64
1	305S20001	SM49E	螺釘 M4 × 3.6	Screw	1	1	1	1	1
2	30528001	KP60	墊片	Washer	1	1	1	1	1
3	30512001	DA80	防護組件	Eye Guide Assy.	1	1	1	1	1
4	30511001	KC69	防護組件	Eye Guide Assy.	1	1	1	1	1
5	S04016	SM132	螺釘 M3.5 × 6	Screw	2	2	2	2	2
6	20131063	MA84	警告牌	Brand	1	1	1	1	1
7	305S11016	SM433	螺釘 M4 × 0.7	Screw	5	5	5	5	5
8	30512002	MA79	支架	Guide	1	1	1	1	1
9	P03025	PM413	定位銷	Pin	1	1	1	1	1
10	300215	VA19P	護罩	Guide	1	1	1	1	1
11	300216	MA82	防護罩	Eye Guide	1	1	1	1	1
12	30526001	PM404	定位銷	Pin	1	1	1	1	1
13	30501005	VA01	機殼下節	Lower Macine	1	1	1	1	1
14	201S17003	SM152	螺釘 SM1/8 × 44	Screw	2	2	2	2	2
15	301S30017	SM910	螺釘	Screw	4	4	4	4	4
16	P03024	PM510	定位銷 φ 5 × 28.5	Pin	2	2	2	2	2
17	30522001	KH48	油封	Oil Seal	1	1	1	1	1
18	S01057	SM44B	螺釘 M4 × 15	Screw	10	10	10	10	10
19	30337001	VA06	商標	Brand	1	1	1	1	1
20	30522001	KH48	油封	Oil Seal	1	1	1	1	1
21	300217	VA05	機頭左蓋	Left Cover	1	1	1	1	1
22	30522002	VA04	密封圈	sticker	1	1	1	1	1
23	30522001	KH48	油封	Oil Seal	3	3	3	3	3
24	30522003	VA24	紙墊	Washer	1	1	1	1	1
25	300218	VA25	左蓋	Left Cover	1	1	1	1	1
26	30522005	VA25-2	油封	Oil Seal	1	1	1	1	1
27	305S12002	SM416	螺釘 M4 × 30	Screw	4	4	4	4	4
28	305110013	VA07P	擋板	Plate	1	1	1	1	1
29	20111005	KC57	油窗蓋	Oil Sight Window	1	1	1	1	1
30	20122018	KC58	油封	Oil Seal	1	1	1	1	1
31	30512005	VA06	防護板	Eye Guide Plate	1	1	1	1	1
32	305S20003	SM670	螺釘	Screw	4	4	4	4	4
33	300219	VA02	上蓋	Top Cover	1	1	1	1	1
34	30522024	A03	油封	Oil Seal	1	1	1	1	1
35	30501004	VA08	機殼上節	Upper Macine	1	1	1	1	1
36	305S12002	SM417	螺釘 SM1/8 × 44	Screw	3	3	3	3	3
37	30511003	VA23	帶輪蓋	Belt Cover Assy.	1	1	1	1	1
38	30537003	VA26	機型牌	Brand	1	1	1	1	1
39	R03001	KA33	鉚釘 2.5*4	Screw	2	2	2	2	2
40	30522004	---	油封	Oil Seal	1	1	1	1	1

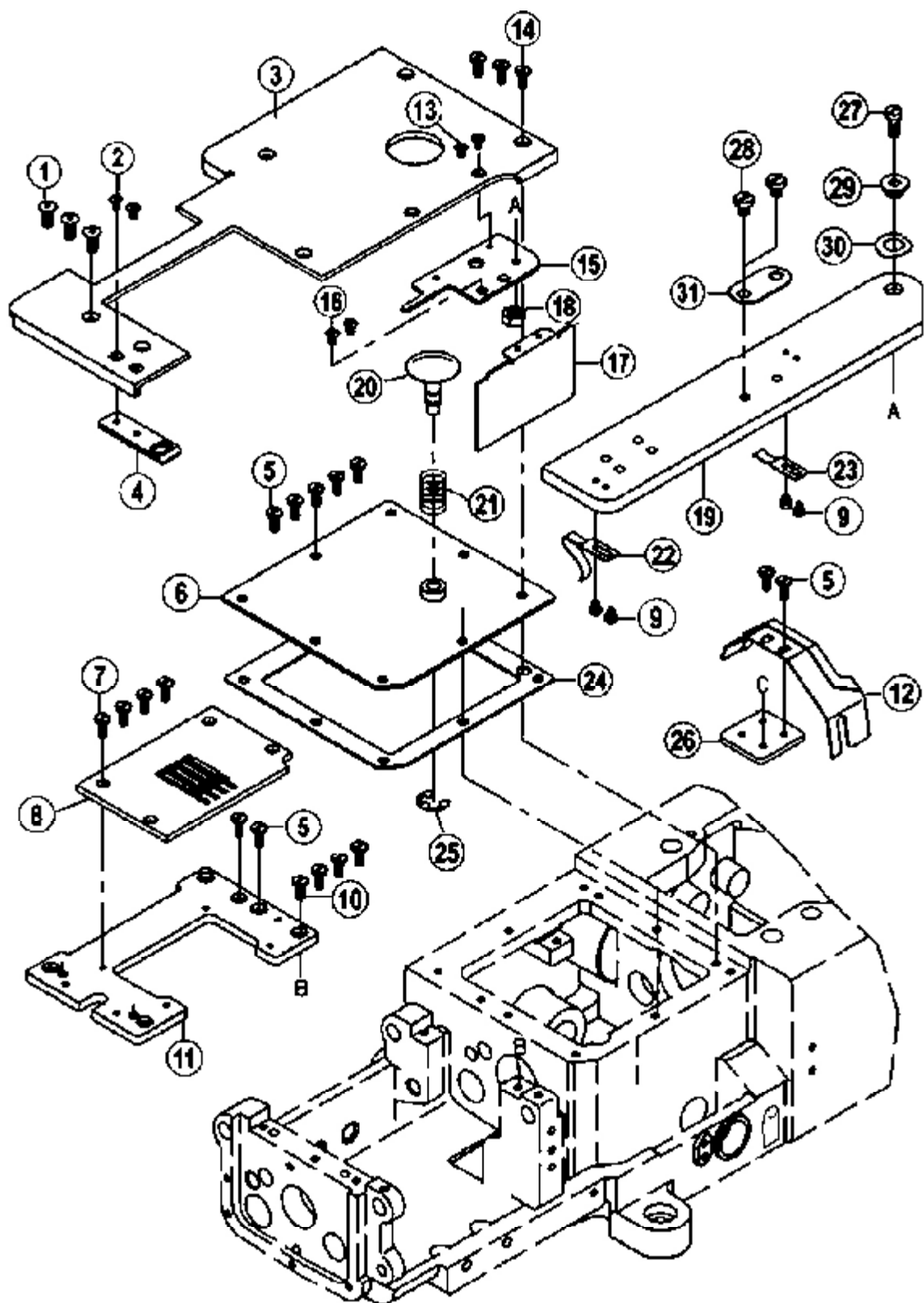

二、縫臺蓋部件 / Cloth Plate assemblies

序號 NO.	件號 Part NO.	參考件號 Ref.Part.NO.	名 稱	Description	數 量 (Number)				
					4針64	6針64	8針64	12針64	13針64
1	S03002	SM496	螺釘 M4 × 3.5	Screw	3	3	3	3	3
2	S02007	SM152	螺釘 M3 × 5	Screw	2	2	2	2	2
3	300220	VB07	縫臺蓋	Cloth Plate Cover	1	1	1	1	1
4	30512008	VB12	卡扣	Carko	1	1	1	1	1
5	305S11016	SM433	螺釘	Screw	9	9	9	9	9
6	30512009	VB02	防油蓋板	Cover	1	1	1	1	1
7	301S17001	SM160	螺釘	Screw	4	4	4	4	4
8	30515009	E9xxx	針板	Needle Plate	1				
	30515003	E9xxx	針板	Needle Plate		1			
	30515004	E9xxx	針板	Needle Plate			1		
	30515002	E9xxx	針板	Needle Plate				1	
	30515005	E9xxx	針板	Needle Plate					1
9	S01058	SM130	螺釘 M3.5 × 4	Screw	4	4	4	4	4
10	S01010	SM433	螺釘 M4 × 8	Screw	4	4	4	4	4
11	30512010	VB06	針板座	Bracket	1				
	30512021	VB07	針板座	Bracket		1	1	1	1
12	3052200600	VB18	搗油板	Feed Bar Oil Scal	1	1	1	1	1
13	305S11005	SM152	螺釘 M4 × 0.7 × 8	Screw	2	2	2	2	2
14	S01038	SM435	螺釘 M4 × 10	Screw	3	3	3	3	3
15	30512011	VB11	鐵皮	Sheet Iron	1	1	1	1	1
16	301S17001	SM152	螺釘 9/64" × 40	Screw	2	2	2	2	2
17	30512012	VB11-1	前門板	Bland	1	1	1	1	1
18	N01004	NM511	螺帽	Nut	1	1	1	1	1
19	300221	VB14	縫臺前蓋板	Side Cover	1	1	1	1	1
20	30502001	VB04	針距調節按鈕	Button	1	1	1	1	1
21	30527001	VB03	調節彈簧	Spring	1	1	1	1	1
22	30512014	VB15	卡扣	KaKo	1	1	1	1	1
23	30512017	VB16	卡扣	KaKo	2	2	2	2	2
24	30522012	VB01	紙墊	Washer	1	1	1	1	1
25	H05003	EM050	卡簧	Ring	1	1	1	1	1
26	30512015	VB19	固定板	Bland	1	1	1	1	1
27	S01051	SM534	螺釘	Screw	2	2	2	2	2
28	S01065	SM630	螺釘 M5 × 6	Screw	1	1	1	1	1
29	30503001	VB13	墊片	Washer	2	2	2	2	2
30	30528002	WMA40	波形墊片	Washer	1	1	1	1	1
31	30512016	VB17	墊片	Washer	1	1	1	1	1

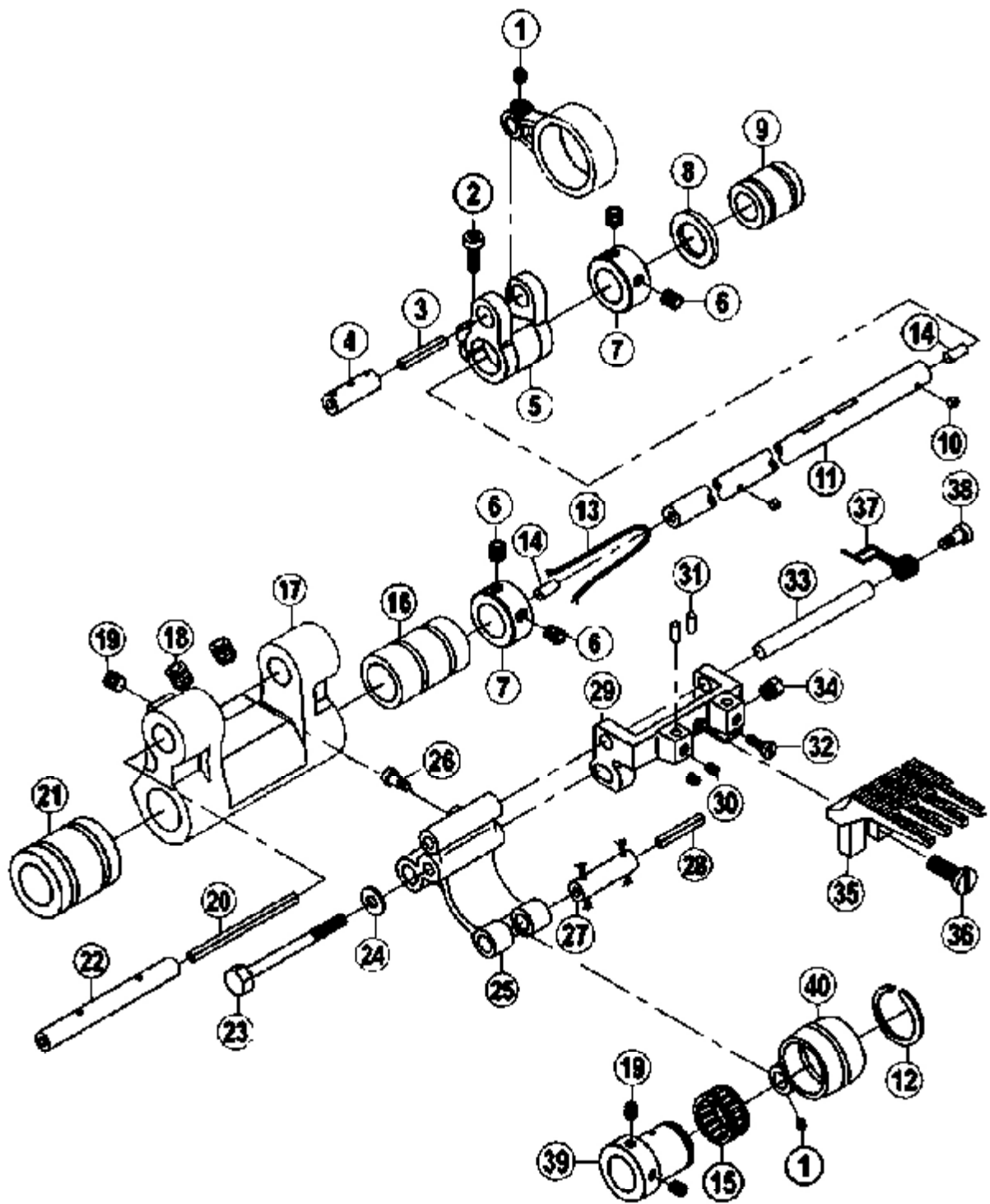

三、送料部件 / Feed assemblies

序號 NO.	件號 Part NO.	參考件號 Ref.Part.NO.	名稱	Description	數量 (Number)				
					4針64	6針64	8針64	12針64	13針64
1	305S14003	SM103	螺釘 M3.5 × 5	Screw	2	2	2	2	2
2	305S13005	SM612	螺釘 M6 × 0.75 × 15	Screw	1	1	1	1	1
3	20123021	VC11	油綫	Oil Wick	1	1	1	1	1
4	30526002	VC08	銷子	Pin	1	1	1	1	1
5	30504001	VC07	曲柄	Crank	1	1	1	1	1
6	S09008	SM502	螺釘 M5 × 5	Screw	4	4	4	4	4
7	30508001	MH73	擋圈	Ring	1	1	1	1	1
8	30508002	CL13	墊片	Washer	1	1	1	1	1
9	30503002	VC09S	銅套	Sleeve	1	1	1	1	1
10	30123009	MS12-4	油棉	Felt	1	1	1	1	1
11	30502002	VC06	送料軸	Shaft	1	1	1	1	1
12	30508004	VC23	卡簧	Spring	1	1	1	1	1
13	20123021	VD30D-2	油綫	Oil Wick	1	1	1	1	1
14	30526004	--- --- ---	鉛堵頭	Pin	1	1	1	1	1
15	30524001	VC24	滾針軸承	Bearing	1	1	1	1	1
16	30503004	VC03S	套筒	Bushing	1	1	1	1	1
17	30504002	VC02	曲柄	Crank	1	1	1	1	1
18	305S14007	SM600	螺釘 M6 × 0.75 × 8	Screw	2	2	2	2	2
19	305S14001	SK270	螺釘 SM11/64 × 40	Screw	3	3	3	3	3
20	20123021	VC13	油綫	Oil Wick	1	1	1	1	1
21	30503005	VC01S	銅套	Bushing	1	1	1	1	1
22	30502003	VC12	銷子	Pin	1	1	1	1	1
23	305S12003	SK496	螺釘 SM11/64 × 40	Screw	1	1	1	1	1
24	W01006	WK01	墊片	Washer	1	1	1	1	1
25	30504003	VC14D	牙架座	Feed Bar	1	1	1	1	1
26	S01061	SM131	螺釘 M3.5 × 5	Screw	1	1	1	1	1
27	30526003	VC21	銷子	Pin	1	1	1	1	1
28	20123021	KM15	油綫	Oil Wick	1	1	1	1	1
29	30506001	VC16D	牙架	Feed	1	1	1	1	1
30	305S14002	SK216	螺釘 SM11/64 × 40	Screw	2	2	2	2	2
31	30526005	PM301	銷子	Pin	1	1	1	1	1
32	S01062	SK213	螺釘 SM1/8 × 44	Screw	1	1	1	1	1
33	30526006	VC18D	銷子	Pin	1	1	1	1	1
34	305S16001	NK55	螺帽	Nut	1	1	1	1	1
35	30514009	D9xxx	牙齒	Feed Dog	1				
	30514003	D9xxx	牙齒	Feed Dog		1			
	30514004	D9xxx	牙齒	Feed Dog			1		
	30514002	D9xxx	牙齒	Feed Dog				1	
	30514005	D9xxx	牙齒	Feed Dog					1
36	305S11001	SK265	螺釘 SM11/64 × 40	Screw	1	1	1	1	1
37	30527002	VC19	彈簧	Spring	1	1	1	1	1
38	305S20004	SK497	螺釘 M3.5 × 2.5	Screw	1	1	1	1	1
39	30510001	VC25	偏心凸輪	Eccent	1	1	1	1	1
40	30505001	VC22D	連杆	Eccent	1	1	1	1	1

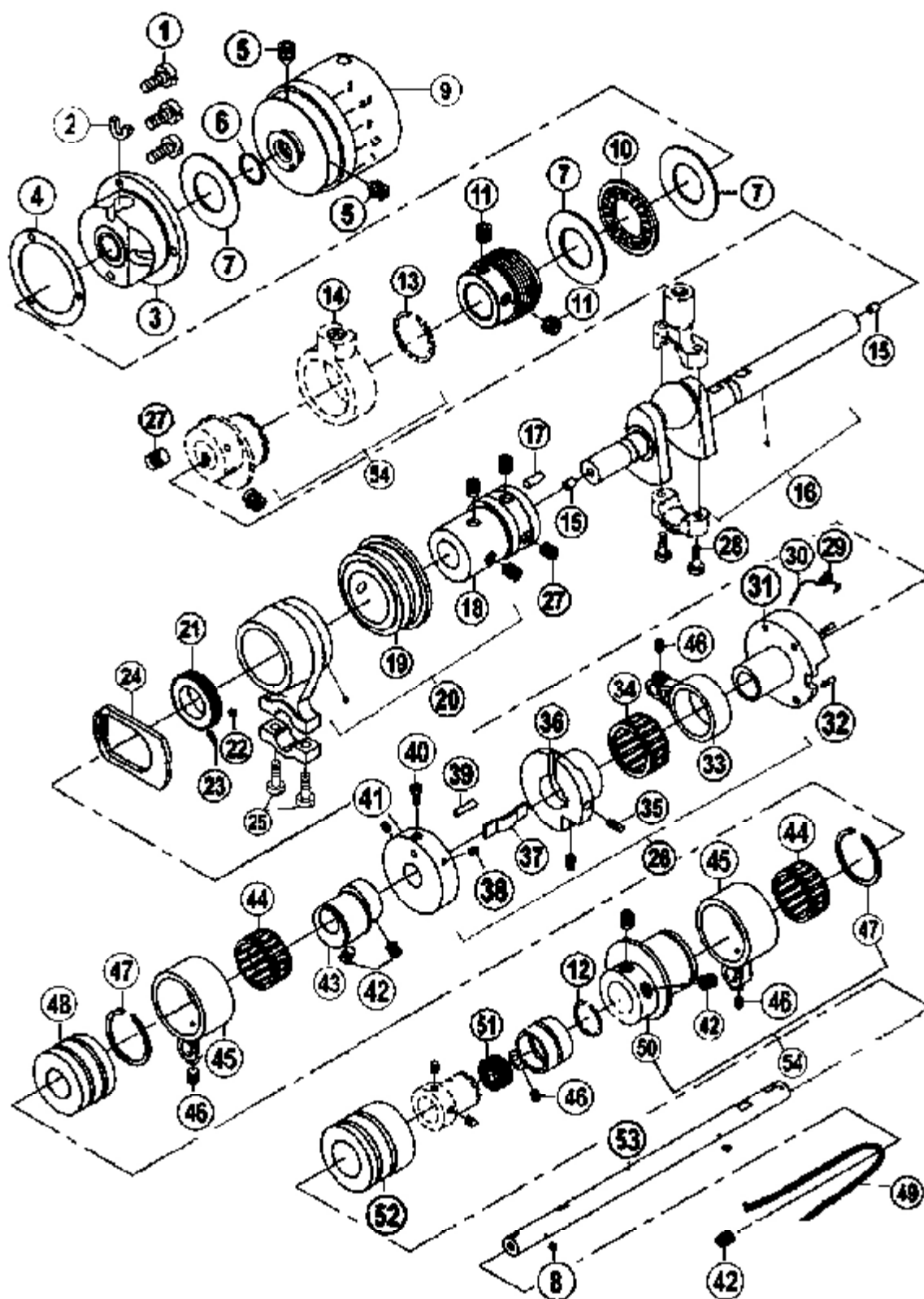

四、主軸部件 / Crankshaft Drive assemblies

序號 NO.	件號 Part NO.	參考件號 Ref.Part.NO.	名稱	Description	數量 (Number)				
					4針64	6針64	8針64	12針64	13針64
1	S01011	SM532	螺釘 M5 × 10	Screw	3	3	3	3	3
2	30523006	VD02-2	油棉	Felt	1	1	1	1	1
3	3050500600	VD02	軸承蓋	Bearing Cover	1	1	1	1	1
4	30522008	VD05	紙墊	Washer	1	1	1	1	1
5	S09007	SM604	螺釘 M6 × 8	Screw	2	2	2	2	2
6	30522020	MD25	油封	Oil Seal	1	1	1	1	1
7	30528003	VD03-2	墊片	Washer	3	3	3	3	3
8	30125009	MS12-4	油棉	Felt	2	2	2	2	2
9	30535002	VD01	皮帶輪	Machine Pulley	1	1	1	1	1
10	30524002	VD03-1	平面滾針軸承	Bearing	1	1	1	1	1
11	S09010	SM602	螺釘 M6 × 5	Screw	2	2	2	2	2
12	30508004	VC23	卡簧	Spring	1	1	1	1	1
13	30508008	VCL03	卡簧	Spring	1	1	1	1	1
14	3051001100	VCL02D	連杆組件	Rod Assembly	1	1	1	1	1
15	30222003	VD07-1	堵頭	Pin	2	2	2	2	2
16	3050402500	VD07	曲柄組件	Crank Assembly	1	1	1	1	1
17	P01007	PM401	銷子	Pin	1	1	1	1	1
18	30510002	VD09	偏心凸輪	Eccent	1	1	1	1	1
19	30505009	VD08	銅套	Bushing	1	1	1	1	1
20	3050402300	----	曲柄球組件	Crank Assembly	1	1	1	1	1
21	30525015	VD46	齒輪	Gear Wheel	1	1	1	1	1
22	305S14009	----	螺釘 SM9/64 × 40	Screw	1	1	1	1	1
23	305S14010	----	螺釘 SM9/64 × 40	Screw	1	1	1	1	1
24	30509020	KP74	針距調節滑塊	Ratchet	1	1	1	1	1
25	305S14008	SM139	螺釘	Screw	2	2	2	2	2
26	3050502100	----	送布組件	Deliver Fabric Assy.	1	1	1	1	1
27	S09002	SM606	螺釘	Screw	5	5	5	5	5
28	305S20008	SK490	螺釘	Screw	2	2	2	2	2
29	S01024	----	送布組件彈簧螺釘M3	Screw	1	1	1	1	1
30	30527011	----	送布組件上彈簧	Spring	1	1	1	1	1
31	30510018	VD43	針距凸輪	Cam	1	1	1	1	1
32	S07001	----	螺釘 M3 × 8.2	Screw	2	2	2	2	2
33	30505024	VD45	連杆	Link	1	1	1	1	1
34	30524005	----	滾針軸承	Bearing	1	1	1	1	1
35	305S15	SK817	螺釘	Screw	2	2	2	2	2
36	30510017	VD44	送布凸輪	Cam	1	1	1	1	1
37	30508010	----	送布凸輪簧	Spring	1	1	1	1	1
38	305S14001	----	螺釘 SM11/64 × 40	Screw	2	2	2	2	2
39	30526030	KP18-1	銷子	Pin	1	1	1	1	1
40	305S11020	SM107	螺釘	Screw	1	1	1	1	1
41	30510016	VD47	送布固定輪	Deliver Wheel	1	1	1	1	1
42	S02013	SM602	螺釘	Screw	5	5	5	5	5
43	30510004	VD23	偏心凸輪	Eccent	1	1	1	1	1
44	30524004	VD24	滾針軸承	Bearing	2	2	2	2	2
45	30505006	VD25	連杆	Rod	2	2	2	2	2
46	305S14003	SM103	螺釘 M3.5 × 5	Screw	4	4	4	4	4
47	30508003	VD26	卡簧	Spring	2	2	2	2	2
48	30505010	VD27	銅套	Bushing	1	1	1	1	1
49	30123015	VD30D	油綫	Oil Wick	1	1	1	1	1
50	30510005	VD31	偏心凸輪	Eccent	1	1	1	1	1
51	30524001	VC24	滾針軸承	Bearing	1	1	1	1	1
52	30505011	VD28	銅套	Bushing	1	1	1	1	1
53	30502005	VD29	主軸	Shaft	1	1	1	1	1
54	3051001100	----	偏心輪組件	Eccent Assembly	1	1	1	1	1

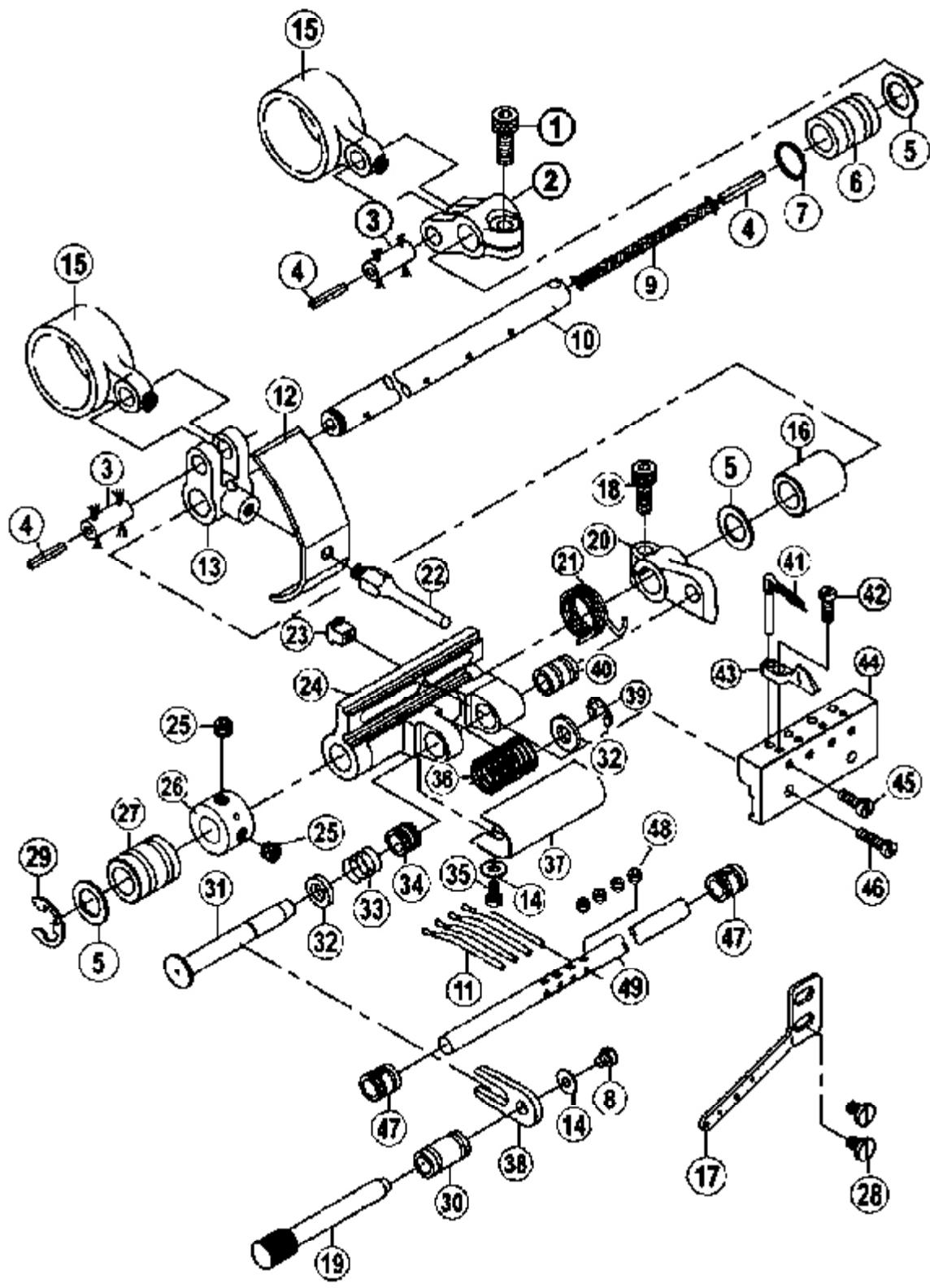

五、勾綫部件 / Thread Takeup assemblies

序號 NO.	件號 Part NO.	參考件號 Ref.Part.NO.	名稱	Description	數量 (Number)				
					4針64	6針64	8針64	12針64	13針64
1	305S13006	SM610	螺釘 M6 × 10	Screw	1	1	1	1	1
2	30504004	VE01	曲柄	Crank	1	1	1	1	1
3	30526008	VF10	銷子	Pin	2	2	2	2	2
4	20123021	VC11	油綫	Oil Wick	1	1	1	1	1
5	20128010	KL11	墊片	Washer	4	4	4	4	4
6	30503012	VE09S	銅套	Bushing	1	1	1	1	1
7	30522010	MH47	密封圈	Gasket	1	1	1	1	1
8	S01058	SM130	螺釘 M3.5 × 4	Screw	1	1	1	1	1
9	20123021	VE04-1	油綫	Oil Wick	1	1	1	1	1
10	30502006	VE04	導針軸	Shaft	1	1	1	1	1
11	30517003	VE30	喂針	Spreader	4	6	8	12	13
12	30512014	VE10D	擋油板	Feed Bar Oil Seal	1	1	1	1	1
13	30504005	VE05	曲柄	Crank	1	1	1	1	1
14	W01005	WM100	墊片	Washer	2	2	2	2	2
15	30505006	VD25	偏心凸輪	Eccent	2	2	2	2	2
16	30503013	VE03S	銅套	Bushing	1	1	1	1	1
17	30513001	VE32	導綫	Thread guide	1				
	30513002	VE32	導綫	Thread guide		1	1	1	1
18	S05004	SM511	螺釘 M5 × 14	Screw	1	1	1	1	1
19	30502007	VE23	調整杆	Adjusting Bar	1	1	1	1	1
20	30504006	VE07	曲柄	Crank	1	1	1	1	1
21	30527004	VF08	彈簧	Spring	1	1	1	1	1
22	305S30002	VE06	打綫杆	Thread Takeup	1	1	1	1	1
23	30509004	VE45	螺帽	Nut	2	2	2	3	3
24	30504007	VE11	導針架固定座	Rivit Seat	1	1	1	1	1
25	201S14002	SK270	螺釘 11/64 × 40	Screw	2	2	2	2	2
26	3050800400	VE13D	擋圈	Coller	1	1	1	1	1
27	30503014	VE14S	銅套	Bushing	1	1	1	1	1
28	305S11016	SM431	螺釘 M4 × 0.7 × 6	Screw	2	2	2	2	2
29	H05011	EM050	卡簧	Spring	1	1	1	1	1
30	30503018	VE27S	銅套	Bushing	1	1	1	1	1
31	30526022	VE15	拉杆	Link	1	1	1	1	1
32	40228017	VE16	墊片	Washer	2	2	2	2	2
33	30527006	VE17	彈簧	Spring	1	1	1	1	1
34	30503016	VE18S	套筒	Bushing	1	1	1	1	1
35	305S12005	SM331	螺釘 1/8 × 44	Screw	1	1	1	1	1
36	30527005	VE21	彈簧	Spring	1	1	1	1	1
37	30512025	VE25	防滴板	Bland	1	1	1	1	1
38	30512026	VE24	比叉	Washer	1	1	1	1	1
39	30529001	EM060	卡簧	Spring	1	1	1	1	1
40	30503015	VE22S	銅套	Bushing	1	1	1	1	1
41	30517002	VE51	導針	Looper	4	6	8	12	
	30517006	VE51	導針	Looper					13
	30517007	VE52	導針(17針用)	Looper					
42	S01062	SK213	螺釘 M3.5 × 6.5	Screw	4	6	8	12	13
43	30517001	VE49	護針	Needle Guard	4	6	8	12	
	30517008	VE50	護針	Needle Guard					1
44	30504028	L9xxx	導針架	Looper Holder	1				
	30504016	L9xxx	導針架	Looper Holder		1			
	30504017	L9xxx	導針架	Looper Holder			1		
	30504009	L9xxx	導針架	Looper Holder				1	
	30504018	L9xxx	導針架	Looper Holder					1
45	305S11002	SK532	螺釘 9/64 × 40	Screw	4	6	8	12	13
46	305S11003	SK237	螺釘	Screw	2	2	2	2	2
47	30503017	VE28S	箭套	Bushing	2	2	2	2	2
48	305S14002	SK329	螺釘 1/8 × 44	Screw	4	6	8	12	13
49	30502034	R9xx4	喂針軸	Shaft	1				
	30502024	R9xx4	喂針軸	Shaft		1			
	30502025	R9xx4	喂針軸	Shaft			1		
	30502029	R9xx4	喂針軸	Shaft				1	
	30502026	R9xx4	喂針軸	Shaft					1

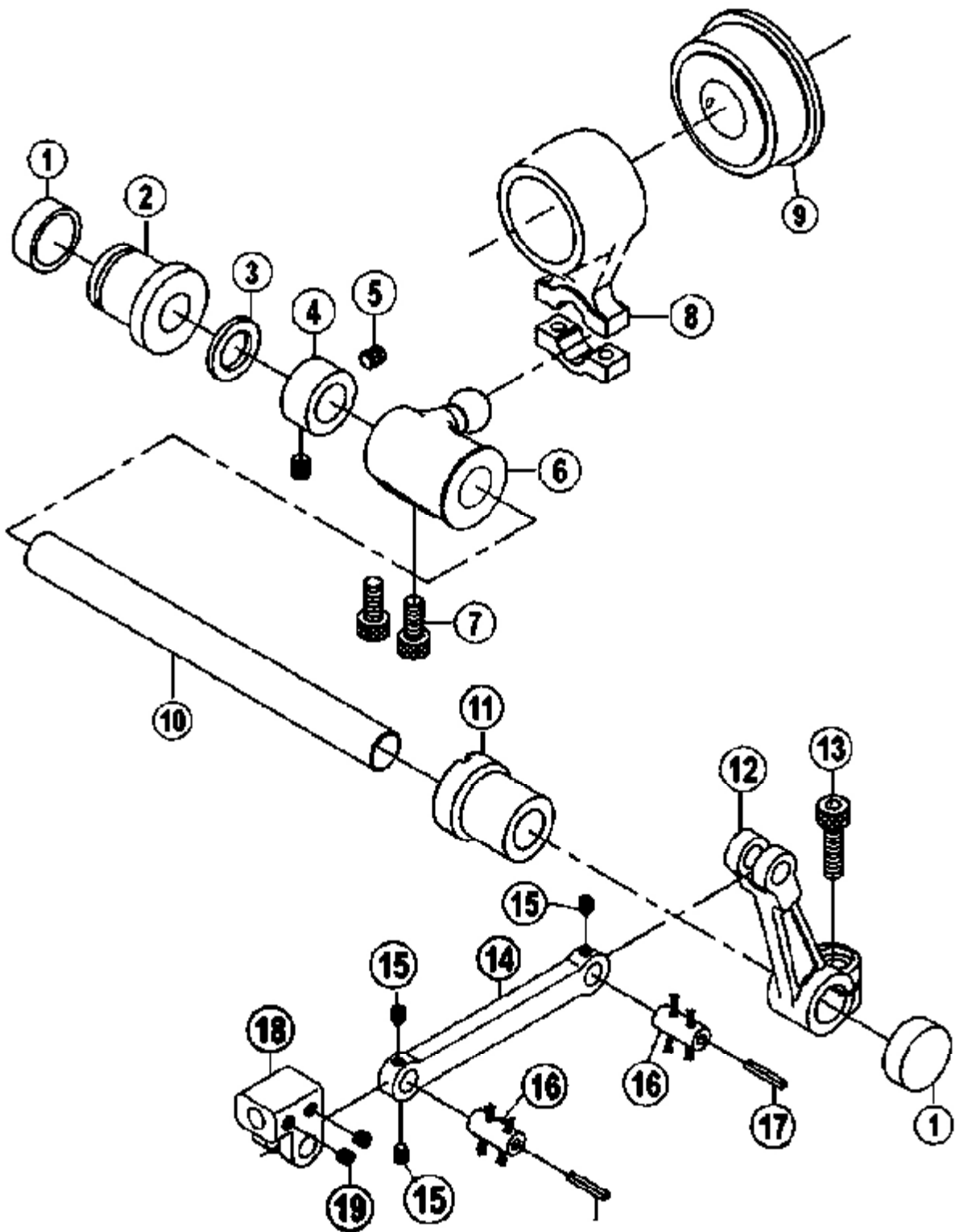

六、喂針部件 / Needle Feeding assemblies

序號 NO.	件號 Part NO.	參考件號 Ref.Part.NO.	名 稱	Description	數 量 (Number)				
					4針64	6針64	8針64	12針64	13針64
1	30522011	MQ21	油封	Oil Seal	2	2	2	2	2
2	30503019	VE44	筒套	Bushing	1	1	1	1	1
3	20128008	MT29D	墊片	Washing	1	1	1	1	1
4	30508001	MH73	擋圈	Ring	1	1	1	1	1
5	S09008	SM502	螺釘 M5 × 5	Screw	2	2	2	2	2
6	30504010	VE42	球曲柄	Crank	1	1	1	1	1
7	305S13006	SM610	螺釘 M6 × 0.75 × 10	Screw	2	2	2	2	2
8	3050500200	VD11	曲柄	Crank	1	1	1	1	1
9	30503009	VD08	筒套	Bushing	1	1	1	1	1
10	30502010	VE41	下橫軸	Shaft	1	1	1	1	1
11	30503020	VE38	銅套	Bushing	1	1	1	1	1
12	30505007	VE36D	連杆	Link	1	1	1	1	1
13	305S13005	SM612	螺釘 M6 × 0.75	Screw	1	1	1	1	1
14	30505008	VE34D	連杆	Link	1	1	1	1	1
15	305S14003	SM103	螺釘 M3.5 × 5	Screw	3	3	3	3	3
16	30526010	VF10	銷子	Pin	2	2	2	2	2
17	20123021	VC11	油綫	Oil Wick	1	1	1	1	1
18	30509005	VE33D	連接滑塊	Slider	1	1	1	1	1
19	305S14001	SK270	螺釘 SM11/64 × 40	Screw	2	2	2	2	2

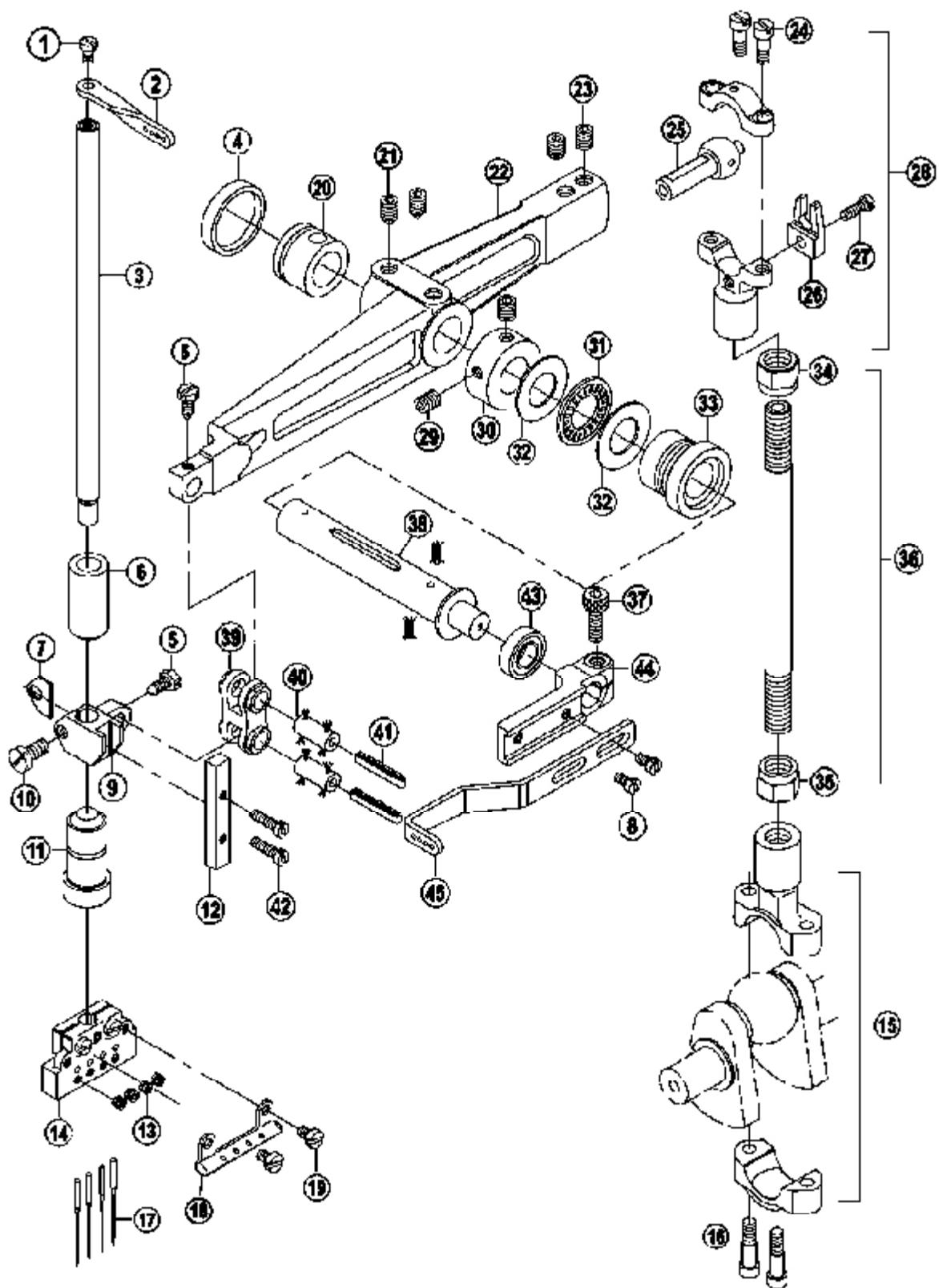

七、針杆部件 / Needle Bar assemblies

序號 NO.	件號 Part NO.	參考件號 Ref.Part.NO.	名稱	Description	數量 (Number)				
					4針64	6針64	8針64	12針64	13針64
1	S01038	SM132	螺釘 M4 × 10	Screw	1	1	1	1	1
2	30513003	VF19	過綫	Thread guide	1				
	30513006	VF19	過綫	Thread guide		1	1	1	1
3	30503011	VF12D	針杆	Needle bar	1	1	1	1	1
4	3052201200	VF07	油封	Oil Seal	1	1	1	1	1
5	305S12004	SM184	螺釘 M3.5 × 8.5	Screw	2	2	2	2	2
6	30503021	VF13	筒套	Bushing	1	1	1	1	1
7	30512027	WM130	墊片	Washer	1	1	1	1	1
8	305S11016	SM431	螺釘 M4 × 0.7 × 6	Screw	2	2	2	2	2
9	30509006	VF09	針杆滑塊	Needle slider	1	1	1	1	1
10	S01011	SM532	螺釘	Screw	1	1	1	1	1
11	30503022	VF14	筒套	Bushing	1	1	1	1	1
12	30509007	VF11D	固定條	Rivet	1	1	1	1	1
13	305S14002	SK216	螺釘 1/8 × 44	Screw	4	6	8	12	13
14	30534009	M9**4	針夾頭	Needle Holer Assy.	1				
	30534003	M9**4	針夾頭	Needle Holer Assy.		1			
	30534004	M9**4	針夾頭	Needle Holer Assy.			1		
	30534002	M9**4	針夾頭	Needle Holer Assy.				1	
	30534005	M9**4	針夾頭	Needle Holer Assy.					1
15	3050402500	VD07	曲柄組件	Crank Assembly	1	1	1	1	1
16	305S20008	SK490	螺釘	Screw	2	2	2	2	2
17	30517004	Uc113	機針(14#)	Needle	4	6	8	12	13
	30517005	Uc113	機針(16#) (4針85用)	Needle					
18	30513004	M9**4-	過綫	Thread guide	1				
	30513007	M9**4-	過綫	Thread guide		1	1	1	
	30513021	M9**4-	過綫	Thread guide					1
19	305S11015	SK239	螺釘 M4 × 0.7 × 8	Screw	2	2	2	2	2
20	30503023	VF06	筒套	Bushing	1	1	1	1	1
21	305S14006	SM601	螺釘 M6 × 0.75 × 9	Screw	2	2	2	2	2
22	30505009	VF01	大杠杆	Lever	1	1	1	1	1
23	305S14007	SM600	螺釘 M6 × 0.75 × 8	Screw	2	2	2	2	2
24	305S20007	SK491	螺釘	Screw	2	2	2	2	2
25	30526011	VF16	曲柄球	Crank	1	1	1	1	1
26	30512028	VF22	上底板	Cover	1	1	1	1	1
27	305S11006	SK277	螺釘	Screw	1	1	1	1	1
28	3050402400	--- ---	曲柄球組件	Crank Assembly	1	1	1	1	1
29	S09008	SM502	螺釘 M5 × 5	Screw	2	2	2	2	2
30	30508006	VF05	擋圈	Ring	1	1	1	1	1
31	30524002	--- ---	平面滾針軸承	Bearing	1	1	1	1	1
32	30528003	VF04	墊片	Washer	2	2	2	2	2
33	30503024	VF03	銅套	Bushing	1	1	1	1	1
34	305S16002	NK54	螺帽	Nut	1	1	1	1	1
35	305S16003	NK53	螺帽	Nut	1	1	1	1	1
36	3050203000	VF23D	傳送杆組件	Connection assy.	1	1	1	1	1
37	S05004	SM511	螺釘	Screw	1	1	1	1	1
38	30502013	VF02	上橫軸	Shaft	1	1	1	1	1
39	30505012	VF08	四眼	Crank	1	1	1	1	1
40	30526008	VF10	銷子	Pin	2	2	2	2	2
41	20123021	VC11	油綫	Oil Seal	1	1	1	1	1
42	S01007	SM438	螺釘 M4 × 13.5	Screw	2	2	2	2	2
43	20622019	--- ---	油封	Oil wick	1	1	1	1	1
44	30509010	VF17	過綫固定座	Thread Guide Rivet Seat	1	1	1	1	1
45	30513005	VF18	過綫	Thread guide	1				
	30513008	VF18P	過綫	Thread guide		1	1	1	1

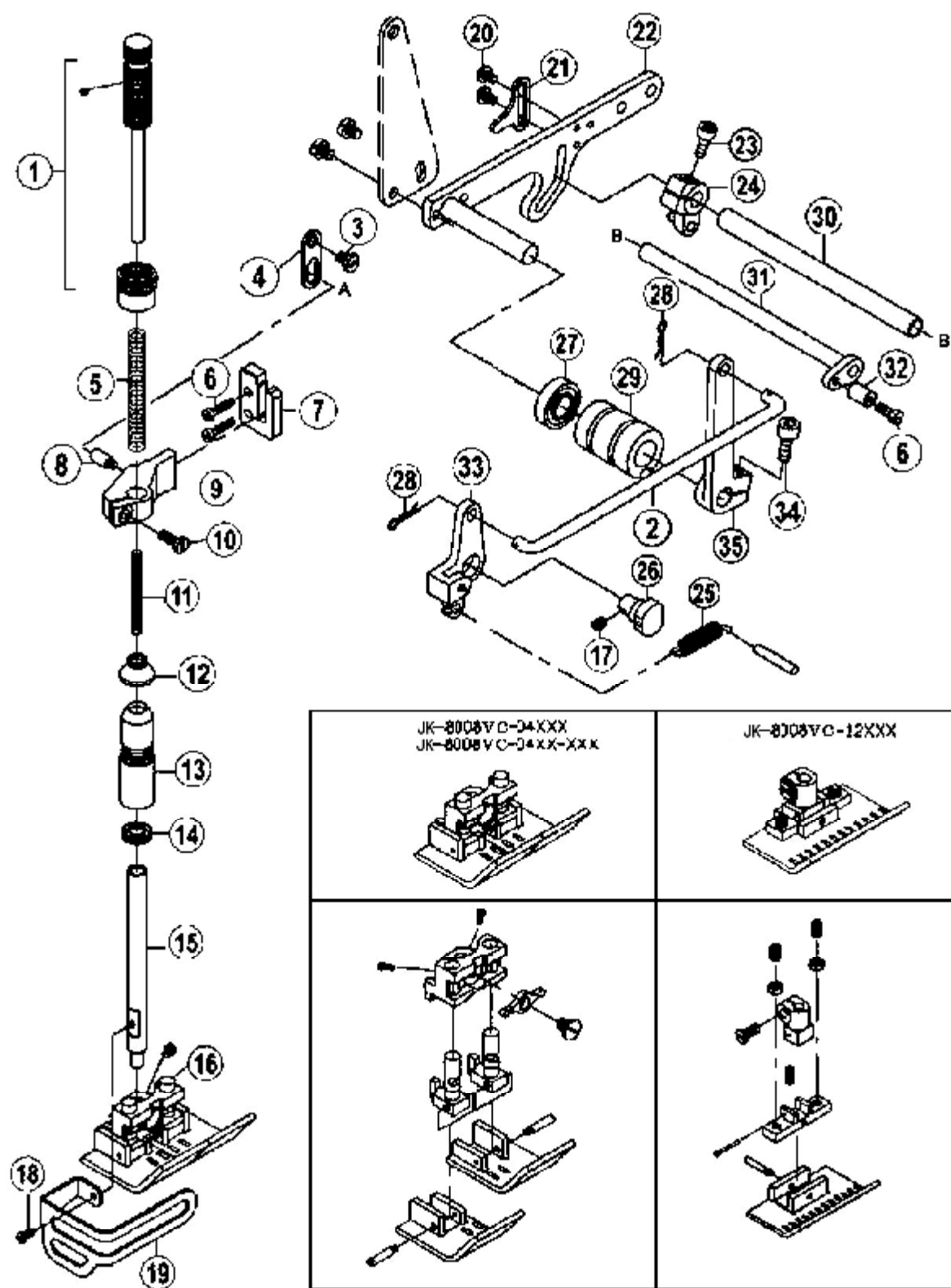

八、壓腳部件 / Presser Foot assemblies

序號 NO.	件號 Part NO.	參考件號 Ref.Part.NO.	名稱	Description	數量 (Number)				
					4針64	6針64	8針64	12針64	13針64
1	3050201400	VJ16	調節杆組件	Adjusting Bar Assy	1	1	1	1	1
2	30512035	VJ09	連接杆	Link	1	1	1	1	1
3	305S20009	SK518	螺釘 M5 × 4	Screw	1	1	1	1	1
4	30512029	VJ13	壓板	Bracket	1	1	1	1	1
5	30527007	MJ03	彈簧	Spring	1	1	1	1	1
6	S01038	SM438	螺釘 M4 × 10	Screw	2	2	2	2	2
7	30509011	VJ20	滑槽	Slider	1	1	1	1	1
8	305S11007	SK502	螺釘 SM9/64 × 40	Screw	1	1	1	1	1
9	30509012	VJ07	滑塊	Slider	1	1	1	1	1
10	305S11001	SK265	螺釘 SM11/64 × 44	Screw	1	1	1	1	1
11	30527008	MJ12	彈簧	Spring	1	1	1	1	1
12	30522014	MJ13	油封	Oil Seal	1	1	1	1	1
13	30503025	VJ21	筒套	Bushing	1	1	1	1	1
14	3052201500	MJ17	油封	Oil Seal	1	1	1	1	1
15	30502015	VJ18	壓腳軸	Shaft	1	1	1	1	1
16	30516009	P9****	壓腳	presser foot assy	1				
	30516003	P9****	壓腳	presser foot assy		1			
	30516004	P9****	壓腳	presser foot assy			1		
	30516002	P9****	壓腳	presser foot assy				1	
	30516005	P9****	壓腳	presser foot assy					1
17	S09008	SM502	螺釘 M5 × 5	Screw	1	1	1	1	1
18	S01027	SM332	螺釘 M3 × 6	Screw	1	1	1	1	1
19	30512030	VJ23	防護罩	Eye Guide	1				
	30512037	VJ23	防護罩	Eye Guide		1	1	1	1
20	305S11016	SM431	螺釘 M4 × 0.7 × 6	Screw	3	3	3	3	3
21	30512031	VJ03	壓板	Bracket	1	1	1	1	1
22	3051203200	VJ05-2	杠杆組件	Lever Assembly	1	1	1	1	1
23	S05004	SM534	螺釘 M5 × 14	Screw	1	1	1	1	1
24	30504011	VJ04	緊固座	Tighten	1	1	1	1	1
25	30527010	VJ14	彈簧	Spring	1	1	1	1	1
26	30526014	VJ12D	銷子	Pin	1	1	1	1	1
27	3052201700	KL20	油封	Oil Seal	1	1	1	1	1
28	30527009	VJ10	開口銷	Pin	2	2	2	2	2
29	30503026	VJ06D	銅套	Bushing	1	1	1	1	1
30	30502016	VJ02	松線管	Thread Guide	1	1	1	1	1
31	3050201700	VJ03	松線軸	Shaft	1	1	1	1	1
32	30510006	VJ01-3	偏心套	Eccent Bushing	1	1	1	1	1
33	30512036	VJ11D	曲柄	Crank	1	1	1	1	1
34	305S13005	SM612	螺釘 M6 × 0.75 × 15	Screw	1	1	1	1	1
35	30504012	VJ08	曲柄	Crank	1	1	1	1	1

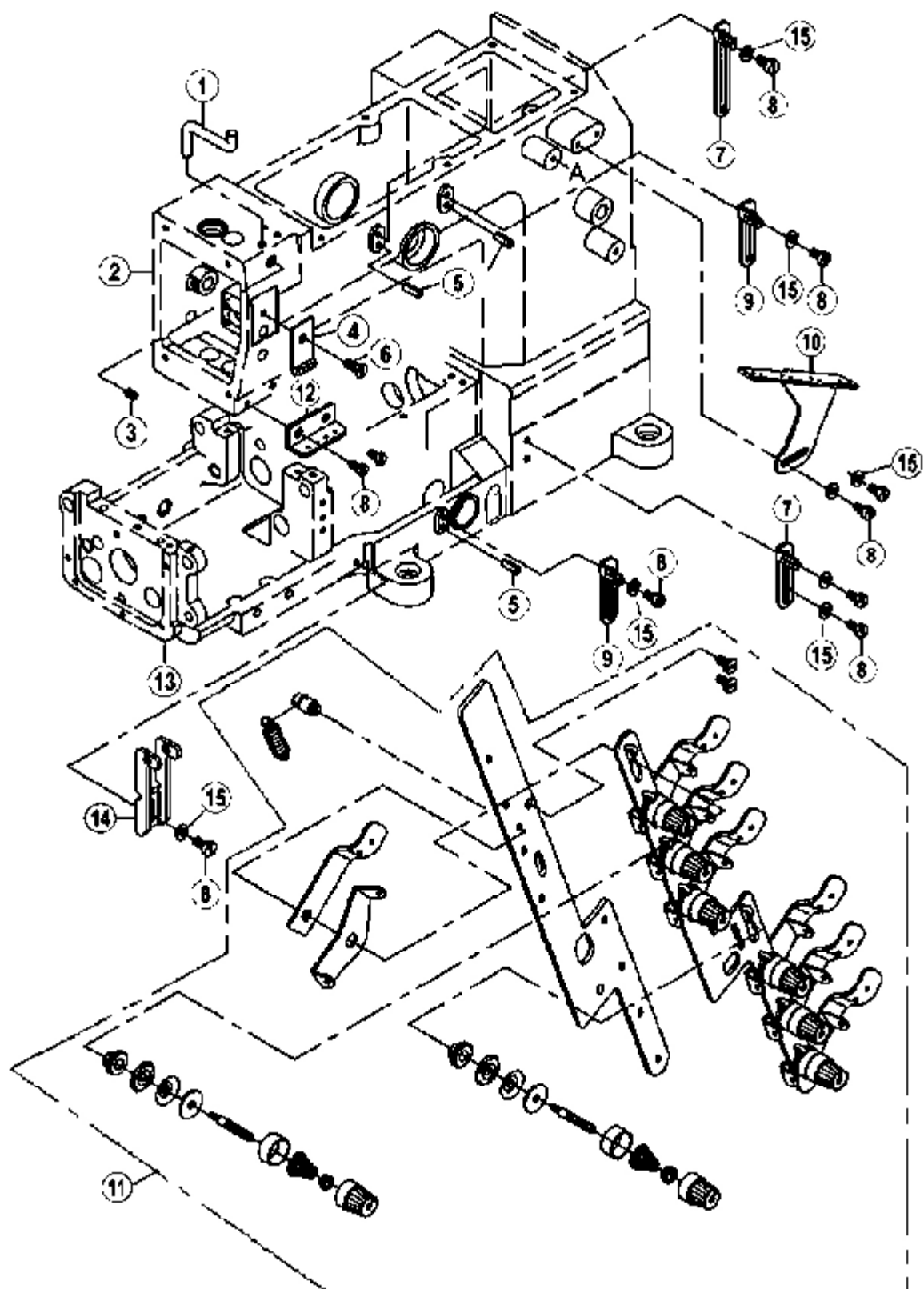

九、夾綫器部件 / Tension Spring assemblies

序號 NO.	件號 Part NO.	參考件號 Ref.Part.NO.	名 稱	Description	數 量 (Number)				
					4針64	6針64	8針64	12針64	13針64
1	30512038	VK13	擋綫架	Bracket	1				
	30512039	VK13	擋綫架	Bracket		1	1	1	1
2	30501004	VA08	機殼上節	Upper Macine	1	1	1	1	1
3	S09012	SM404	螺釘 M4 × 5	Screw	1	1	1	1	1
4	30513009	VK15	過綫	Thread Guide	1				
	30513015	VK15	過綫	Thread Guide		1	1	1	1
5	P03025	PM413	定位銷	Pin	3	2	2	2	2
6	S02003	SM450	螺釘 M4 × 5	Screw	1	1	1	1	1
7	30513010	VK18	過綫	Thread Guide	2				
	30513016	VK18	過綫	Thread Guide		2	2	2	2
8	305S11016	SM431	螺釘 M4 × 0.7 × 6	Screw	10	7	7	7	7
9	30513012	VK11	過綫	Thread Guide	2				
	30513017	VK11	過綫	Thread Guide		1	1	1	1
10	30513011	VK22	過綫	Thread Guide	1	1	1	1	1
11	30513019	VK06	夾綫器組件	Tension Spring Assy	1				
	30531033	VK06	夾綫器組件	Tension Spring Assy				1	1
	3053100100	VK07	夾綫器組件	Tension Spring Assy		1	1		
12	30513013	VK17	過綫	Thread Guide	1	1	1	1	1
13	30501005	VA01	機殼下節	Lower Macine	1	1	1	1	1
14	30513014	VK07	過綫	Thread Guide	1				
	30513019	VK07	過綫	Thread Guide		1	1	1	1
15	20612062	MW400	墊片	Washer	8	7	7	7	7

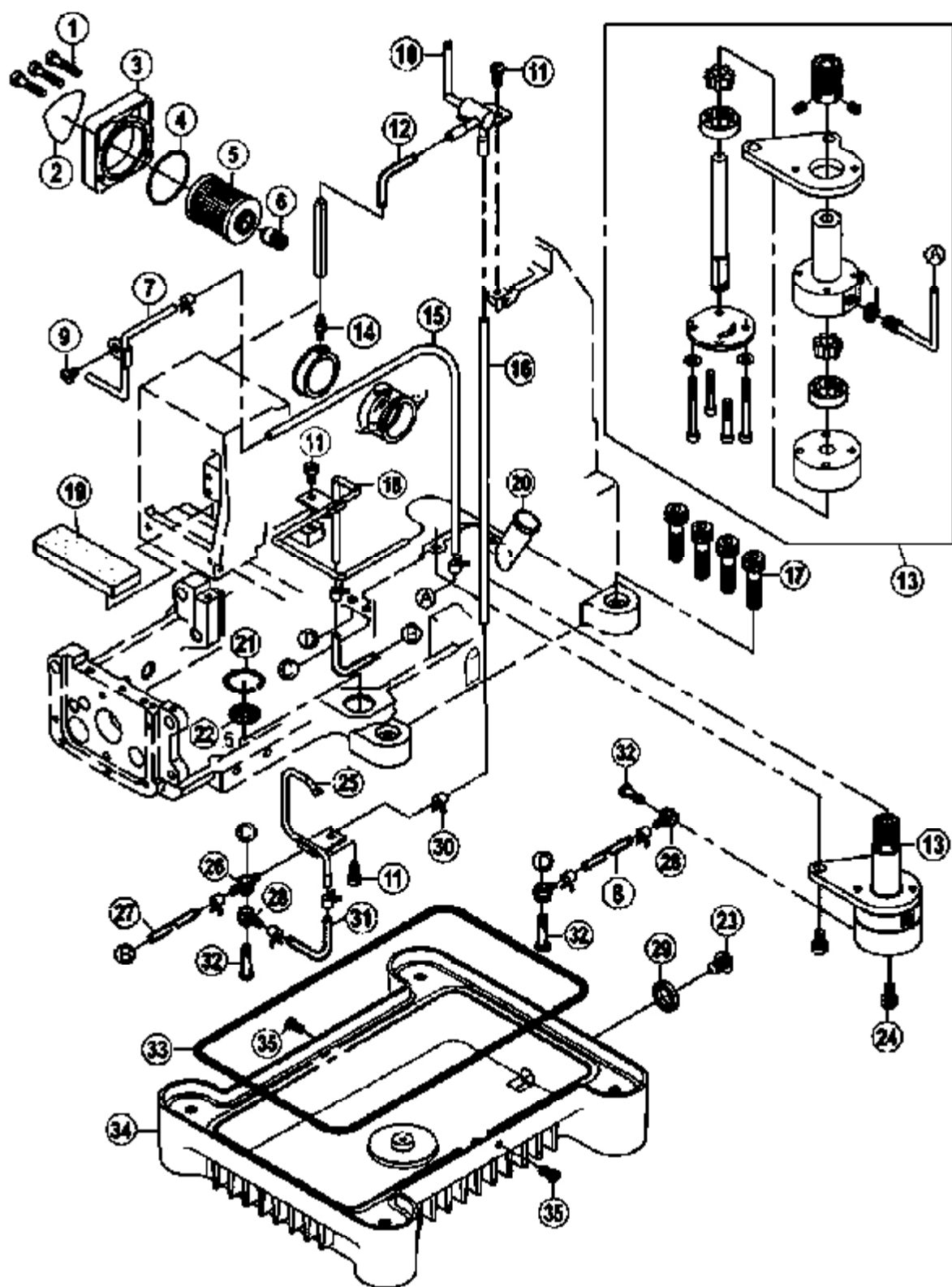

十、油泵部件 / Lubrication assemblies

序號 NO.	件號 Part NO.	參考件號 Ref.Part.NO.	名 稱	Description	數 量 (Number)				
					4針64	6針64	8針64	12針64	13針64
1	S01057	SM447	螺釘 M4 × 15	Screw	3	3	3	3	3
2	20337005	KT18	商標	Brand	1	1	1	1	1
3	20301005	KT16	濾清器蓋	Cover	1	1	1	1	1
4	20322004	KT17	密封圈	Sticker	1	1	1	1	1
5	20136001	K114	濾清器	Filter Element	1	1	1	1	1
6	30503027	ML50	銅接頭	pipe	1	1	1	1	1
7	30521012	VL14	油管	Tube	1	1	1	1	1
8	30112021	VL19	油管	Tube	1	1	1	1	1
9	305S11016	SM431	螺釘 M4 × 0.7 × 6	Screw	1	1	1	1	1
10	30521013	VL11	油管	Tube	1	1	1	1	1
11	305S11016	SM435	螺釘 M4 × 0.7 × 6	Screw	3	3	3	3	3
12	30121022	VL16	油管	Tube	1	1	1	1	1
13	3052000100	ML01	油泵	Pump	1	1	1	1	1
14	30536001	VL12	油管接頭	Joint	1	1	1	1	1
15	30121022	VL15	油管	Tube	1	1	1	1	1
16	30121022	VL17	油管	Tube	1	1	1	1	1
17	305S13003	SM812	螺釘 M8 × 25	Screw	4	4	4	4	4
18	3052101300	VL07	油管組件	Tube Assemblby	1	1	1	1	1
19	30523010	VL13	油棉	Felt	1	1	1	1	1
20	30511004	VL06D	油窗	Oil Window	1	1	1	1	1
21	H01005	EM164	卡簧	Spring	1	1	1	1	1
22	30512040	MR15	濾網	filter	1	1	1	1	1
23	305S11010	SK310	放油螺釘SM3/8×28	Screw	1	1	1	1	1
24	305S13004	SM611	螺釘 M6 × 14.8	Screw	2	2	2	2	2
25	3052101200	VL21	油管組件	Tube Assemblby	1	1	1	1	1
26	30136004	MW05	油管接頭	Joint	1	1	1	1	1
27	30121022	VL20	油管	Tube	1	1	1	1	1
28	30136001	KT24	接頭	Joint	3	3	3	3	3
29	20528014	KT56	放油螺釘密封圈	Sticker	1	1	1	1	1
30	20129002	KT26*11	卡口	Ring	9	9	9	9	9
31	30121022	VL20	油管	Tube	1	1	1	1	1
32	301S30013	SK304	螺釘 SM1/4 × 40	Screw	2	2	2	2	2
33	30522018	VL02	油封	Oil Seal	1	1	1	1	1
34	30501006	VL01	油盤	Oil Reservoir Assy	1	1	1	1	1
35	S01058	--- --- ---	螺釘 M3.5 × 4	Screw	2	2	2	2	2

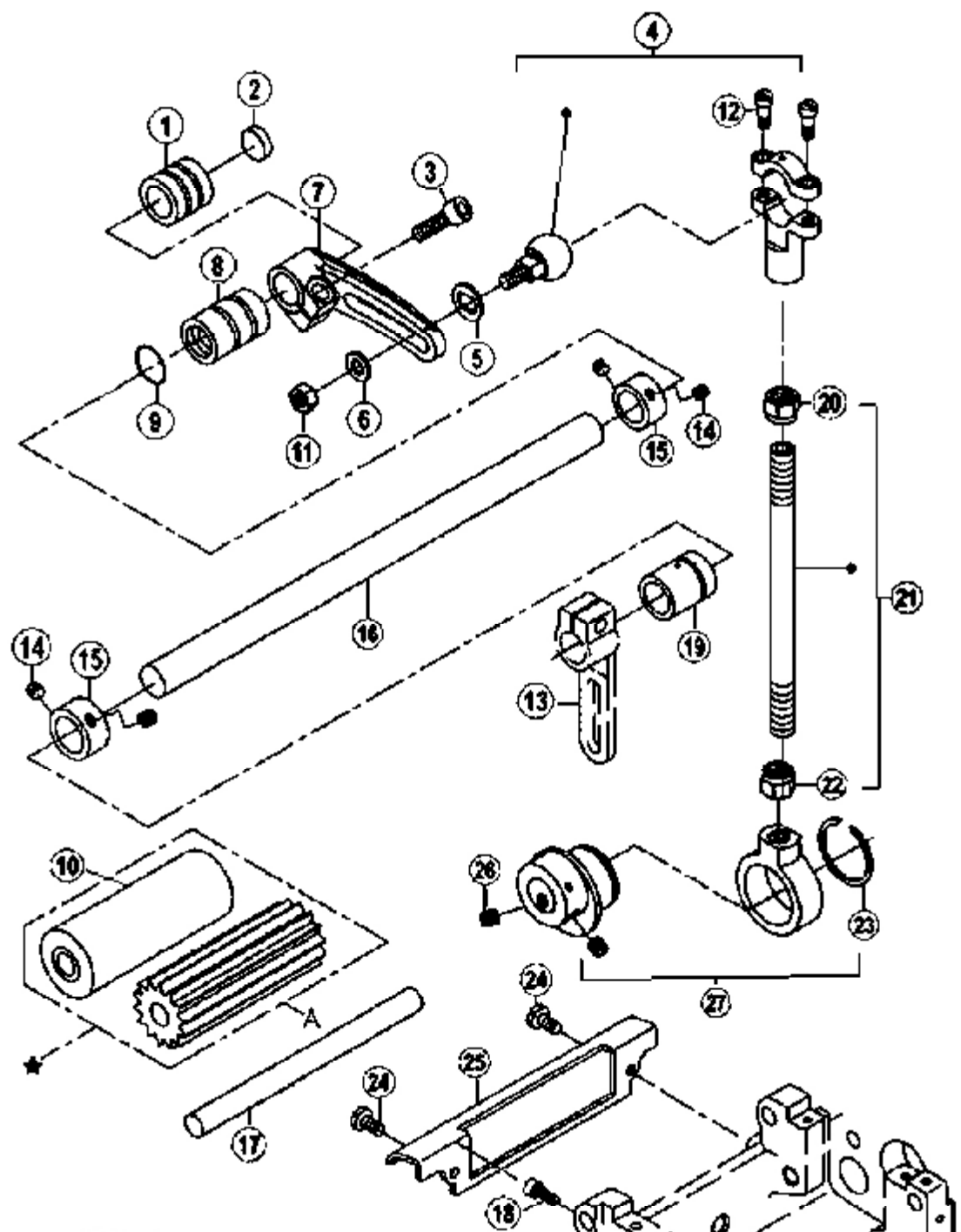

★ 滾輪使用方式

齒形	平 輪				齒 輪			
	PU		黑色橡膠		鍍昇輪		鋁	
材質	短軸	長軸	短軸	長軸	短軸	長軸	短軸	長軸
上滾輪	VCL1E	VCL16P	VCL16Q	VCL16R	VCL09 (22T)	VCL09P (22T)	VCL18Q (27T)	VCL18R (27T)
下滾輪		VCL20P		VCL20R	VCL33 (14T)	VCL33P (16T)	VCL55W	改良齒輪22T

十一、傳送部件 / Transmission assemblies

序號 NO.	件號 Part NO.	參考件號 Ref.Part.NO.	名 稱	Description	數 量 (Number)				
					4針64	6針64	8針64	12針64	13針64
1	30503028	VCL07	銅套	Bushing	1	1	1	1	1
2	30522019	CL14	油封	Oil Seal	1	1	1	1	1
3	305S13005	SM617	螺釘M6 × 0.75 × 15	Screw	1	1	1	1	1
4	3050402600	VCL05	曲柄球組件	Crank Assembly	1	1	1	1	1
5	30512045	VCL05-1	墊片	Washer	1	1	1	1	1
6	40228017	WM600	墊片	Washer	1	1	1	1	1
7	30504013	VCL06	曲柄	Crank	1	1	1	1	1
8	30503029	VCL09	銅套	Bushing	1	1	1	1	1
9	30522020	VCL10	油封	Oil Seal	1	1	1	1	1
10	30522027	VCL28	壓輪組件	Press Wheel Assy.	1	1	1	1	1
11	305S16007	NM611	螺帽	Nut	1	1	1	1	1
12	305S20007	SK491	螺釘 11/64 × 40	Screw	2	2	2	2	2
13	30505010	VCL04	連杆組件	Link Assembly	1	1	1	1	1
14	S10014	SM501	螺釘 M5 × 4	Screw	4	4	4	4	4
15	30508007	VCL11	擋圈	Ring	2	2	2	2	2
16	30502020	VCL12	后拖輪傳送軸	Crank	1	1	1	1	1
17	30502019	VCL27	壓輪軸	Shaft	1	1	1	1	1
18	S09012	--- --- ---	螺釘 M4 × 5	Screw	1	1	1	1	1
19	30503030	VCL13	銅套	Bushing	1	1	1	1	1
20	305S16002	NK54	螺帽	Nut	1	1	1	1	1
21	3050203100	--- --- ---	連杆組件	connection Assy	1	1	1	1	1
22	305S16003	NK53	螺帽	Screw	1	1	1	1	1
23	30508009	VCL03	卡簧	Spring	1	1	1	1	1
24	S01005	SM431	螺釘	Screw	2	2	2	2	2
25	30512046	VCL32	防護板	Eye Guide	1	1	1	1	1
26	S09002	SM603	螺釘	Screw	2	2	2	2	2
27	3051001100	VCL01	偏心輪組件	Eccent Assy	1	1	1	1	1

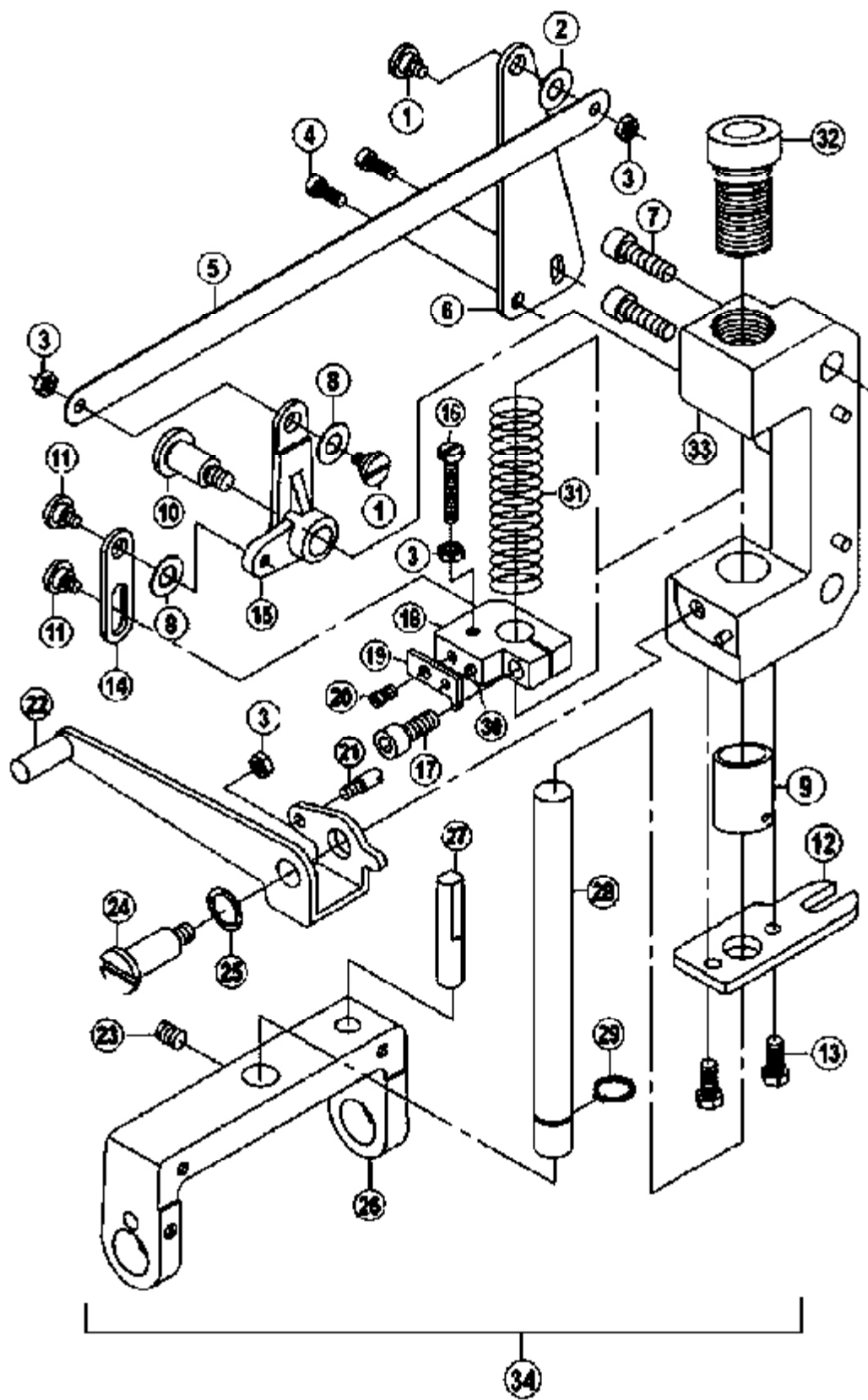

十二、后凸輪架部件 / After Cam Fight assemblies

序號 NO.	件號 Part NO.	參考件號 Ref.Part.NO.	名稱	Description	數量 (Number)				
					4針64	6針64	8針64	12針64	13針64
1	305S20010	SM491	螺釘	Screw	1	1	1	1	1
2	30528011	CL31	墊片	Washer	1	1	1	1	1
3	N01001	NM410	螺帽	Nut	1	1	1	1	1
4	S01065	SM531	螺釘 M5 × 6	Screw	2	2	2	2	2
5	30512047	VCL25	鐵皮連杆	Sheet Iron Link	1	1	1	1	1
6	30512048	VCL35	壓板	Bracket	1	1	1	1	1
7	S05031	SM614	螺釘 M6 × 20	Screw	2	2	2	2	2
8	30528011	CL31	墊片	Washer	1	1	1	1	1
9	30503031	CL26	銅套	Bushing	1	1	1	1	1
10	305S20011	SM681	螺釘	Screw	1	1	1	1	1
11	305S20012	SM492	螺釘	Screw	1	1	1	1	1
12	3051205100	CL33	調節板	Regulator Plate	1	1	1	1	1
13	L02012	SM520	螺釘	Screw	2	2	2	2	2
14	30512049	VCL23	壓板	Bracket	1	1	1	1	1
15	30504014	VCL24	曲柄	Crank	1	1	1	1	1
16	S01018	SM440	螺釘 M4 × 20	Screw	1	1	1	1	1
17	S05031	SM617	螺釘 M6 × 20	Screw	1	1	1	1	1
18	30509013	VCL22	彈簧擋板	Spring Plate	1	1	1	1	1
19	30512050	VCL34	壓板	Bracket	1	1	1	1	1
20	S01055	SM448	螺釘 M4 × 6	Screw	1	1	1	1	1
21	305S11011	SM472	螺釘	Screw	1	1	1	1	1
22	3051205100	CL33	調節板	Regulator Plate	1	1	1	1	1
23	S09007	SM603	螺釘 M6 × 8	Screw	1	1	1	1	1
24	305S20013	SM682	螺釘	Screw	1	1	1	1	1
25	30528012	CL34	壓板	Bracket	1	1	1	1	1
26	3050100800	VCL18	壓輪架	Press Wheel Fight	1	1	1	1	1
27	30526020	VCL19	銷子	Pin	1	1	1	1	1
28	30502022	VCL30	軸	Shaft	1	1	1	1	1
29	H04001	EM123	卡簧	Spring	1	1	1	1	1
30	30526017	PM302	銷子	Pin	1	1	1	1	1
31	30527011	CL28	彈簧	Spring	1	1	1	1	1
32	305S30006	CL25	調節螺釘	Adjusting Screw	1	1	1	1	1
33	30501007	VCL21	壓腳架	Finger Guide	1	1	1	1	1
34	305901400	--- ---	后凸輪組件(齒輪式)	After Cam Assembly	1	1	1	1	1
	305901500	--- ---	后凸輪組件(齒輪式)	After Cam Assembly	1	1	1	1	1
	305901700	--- ---	后凸輪組件(光滑式)	After Cam Assembly	1	1	1	1	1

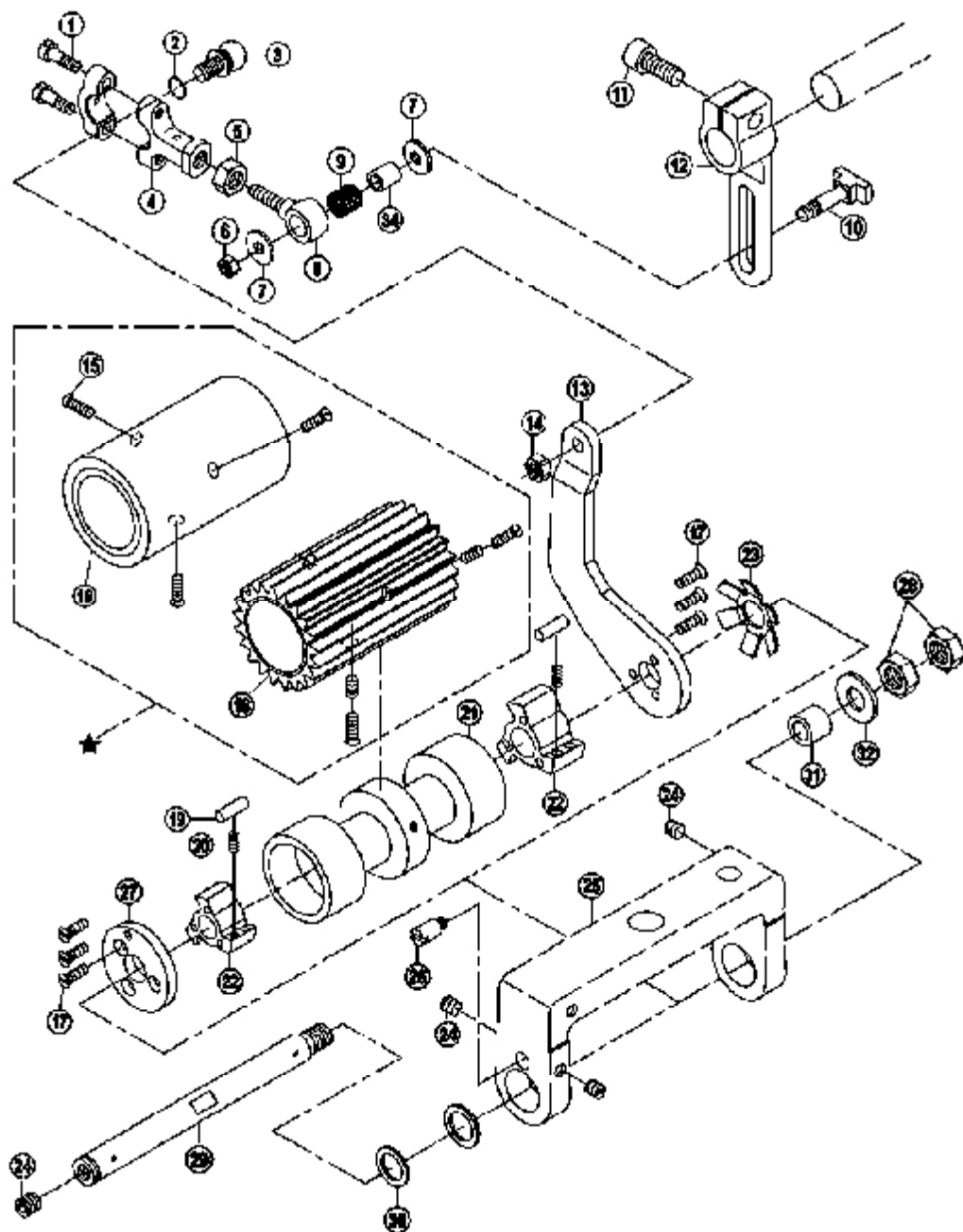

滾輪使用方式

齒形	平 輪				齒 輪			
材質	PU		黑色橡膠		鐵非鐵		鐵	
長度	短輪	長輪	短輪	長輪	短輪	長輪	短輪	長輪
上滾輪	代號 VCL16	VCL16P VCL16Q	VCL16R	VCL16R	VCL08 (22T) VCL37 (27T)	VCL15P (22T) VCL37P (27T)	VCL08 9克鋼線22T	VCL08K 9克鋼線22T
下滾輪		VCL28P		VCL28R	VCL33 (14T) VCL33P (16T)		VCL33K 9克鋼線22T	

十三、后凸輪部件 / After Cam assemblies

序號 NO.	件號 Part NO.	參考件號 Ref.Part.NO.	名 稱	Description	數 量 (Number)				
					4針64	6針64	8針64	12針64	13針64
1	305S30007	SM524	螺釘 M5 × 8.5	Screw	1	1	1	1	1
2	W01004	CL48	墊圈5	Washer	2	2	2	2	2
3	30526011	CL49	曲柄球	Iron Cover	1	1	1	1	1
4	30503034	CL50	連杆	Bearing	1	1	1	1	1
5	3050501700	CL51	連杆組件	connection Assy	1	1	1	1	1
6	N01004	NM511	螺母	Nut	1	1	1	1	1
7	W01004	CL48	墊圈5	Washer	1	1	1	1	1
8	30505020	CL50	連杆	Bearing	1	1	1	1	1
9	B07011	CL49	滾針軸承	Iron Cover	1	1	1	1	1
10	305S30009	CL47	螺釘	Screw	1	1	1	1	1
11	S05037	SM612	螺釘 M6 × 15	Screw	1	1	1	1	1
12	30504015	VCL14	曲柄	Crank	1	1	1	1	1
13	30512055	CL37	衝壓件鐵臂	Jib	1	1	1	1	1
14	N01004	NM511	螺母M5	Nut	1	1	1	1	1
15	S03003	SM451	螺釘 M4 × 6	Screw	3	3	3	3	3
16	3061000200	VCL16	后凸輪組件	After Cam Assy	1	1	1	1	1
17	S02014	SK373	螺釘 M3.5 × 8.5	Screw	5	5	5	5	5
18	30625003	VCL08	壓輪組件	Press Wheel	1	1	1	1	1
19	30526021	LF39	圓柱銷	Pin	2	2	2	2	2
20	30527012	LF38	彈簧	Spring	2	2	2	2	2
21	30503035	VCL15	齒輪套	Gear Wheel Cover	1	1	1	1	1
22	30525010	LF37	齒輪	Gear Wheel	2	2	2	2	2
23	30512056	CL38	蝶形卡簧	Spring	1	1	1	1	1
24	S09008	SM502	螺釘 M5 × 5	Screw	4	4	4	4	4
25	3050100800	VCL18	壓輪架	Press Wheel Fight	1	1	1	1	1
26	305S11012	SM470	螺釘	Screw	1	1	1	1	1
27	30512057	CL45	壓板	Bracket	1	1	1	1	1
28	N01008	NM810	螺母 M8	Nut	2	2	2	2	2
29	30502023	VCL17	軸	Shaft	1	1	1	1	1
30	-----	CL41	墊片	Washer	5	5	5	5	5
31	30503036	VCL31	軸套	Bushing	1	1	1	1	1
32	W01010	WM800	墊圈8	Washer	1	1	1	1	1

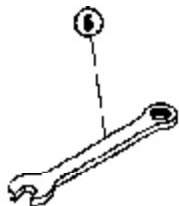
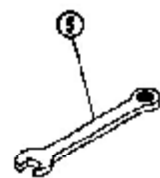
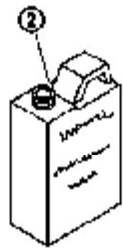

1.5



2



2.5



3

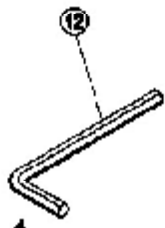

4

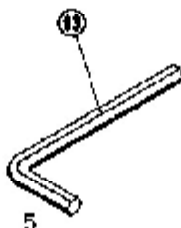

5

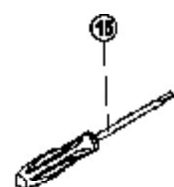
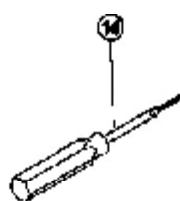

6



17

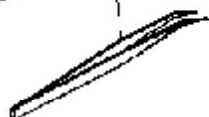

18



19

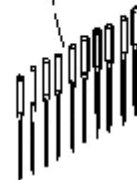

20

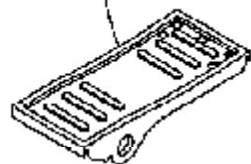

四針十二針(每使用說明書)



21

22



十四、附件部件(1) / Accessories Assemblies

序號 NO.	件號 Part NO.	參考件號 Ref.Part.NO.	名 稱	Description	數 量 (Number)				
					4針64	6針64	8針64	12針64	13針64
1	30531001	MY01	純白油	Oil	1	1	1	1	1
2	30531002	MY02	硅油	Silicon Oil	1	1	1	1	1
3	30511006	MY03	空油壺	Oil Can	1	1	1	1	1
4	30511007	KY04	漏門	Oil Funnel	1	1	1	1	1
5	30531003	KY07	7mm六角扳手	Spanner(7mm)	1把	1把	1把	1把	1把
6	30531004	KY08	8mm六角扳手	Spanner(8mm)	1把	1把	1把	1把	1把
7	30531005	KY09	9mm六角扳手	Spanner(9mm)	1把	1把	1把	1把	1把
8	30531006	MY09	1.5mm內六角扳手	Inner-hexagon Driver(1.5mm)	1把	1把	1把	1把	1把
9	30531007	MY08	2mm內六角扳手	Inner-hexagon Driver(2mm)	1把	1把	1把	1把	1把
10	30531008	MY10	2.5mm內六角扳手	Inner-hexagon Driver(2.5mm)	1把	1把	1把	1把	1把
11	30531009	MY11	3mm內六角扳手	Inner-hexagon Driver(3mm)	1把	1把	1把	1把	1把
12	30531010	MY12	4mm內六角扳手	Inner-hexagon Driver(4mm)	1把	1把	1把	1把	1把
13	30531011	KY11	5mm內六角扳手	Inner-hexagon Driver(5mm)	1把	1把	1把	1把	1把
14	30531012	KY14	大號一字螺釘刀	Screw Driver	1把	1把	1把	1把	1把
15	30531013	KY17	中號一字螺釘刀	Screw Driver	1把	1把	1把	1把	1把
16	30531014	KY16	小號一字螺釘刀	Screw Driver	1把	1把	1把	1把	1把
17	30531015	KY18	镊子	Tweezer	1	1	1	1	1
18	30531017	KT14	濾油器	Oil Filter	1	1	1	1	1
19	30617004	Uo113	機針	Needle	1包	1包	1包	1包	1包
20	30531016	KY20D	脚踏板	Presser Foot Base	1	1	1	1	1
21	30531029	--- --- ---	說明書零件樣本	Parts list Instruction book	1	1	1	1	1
22	30531018	KY21	鏈條	Chain	1	1	1	1	1

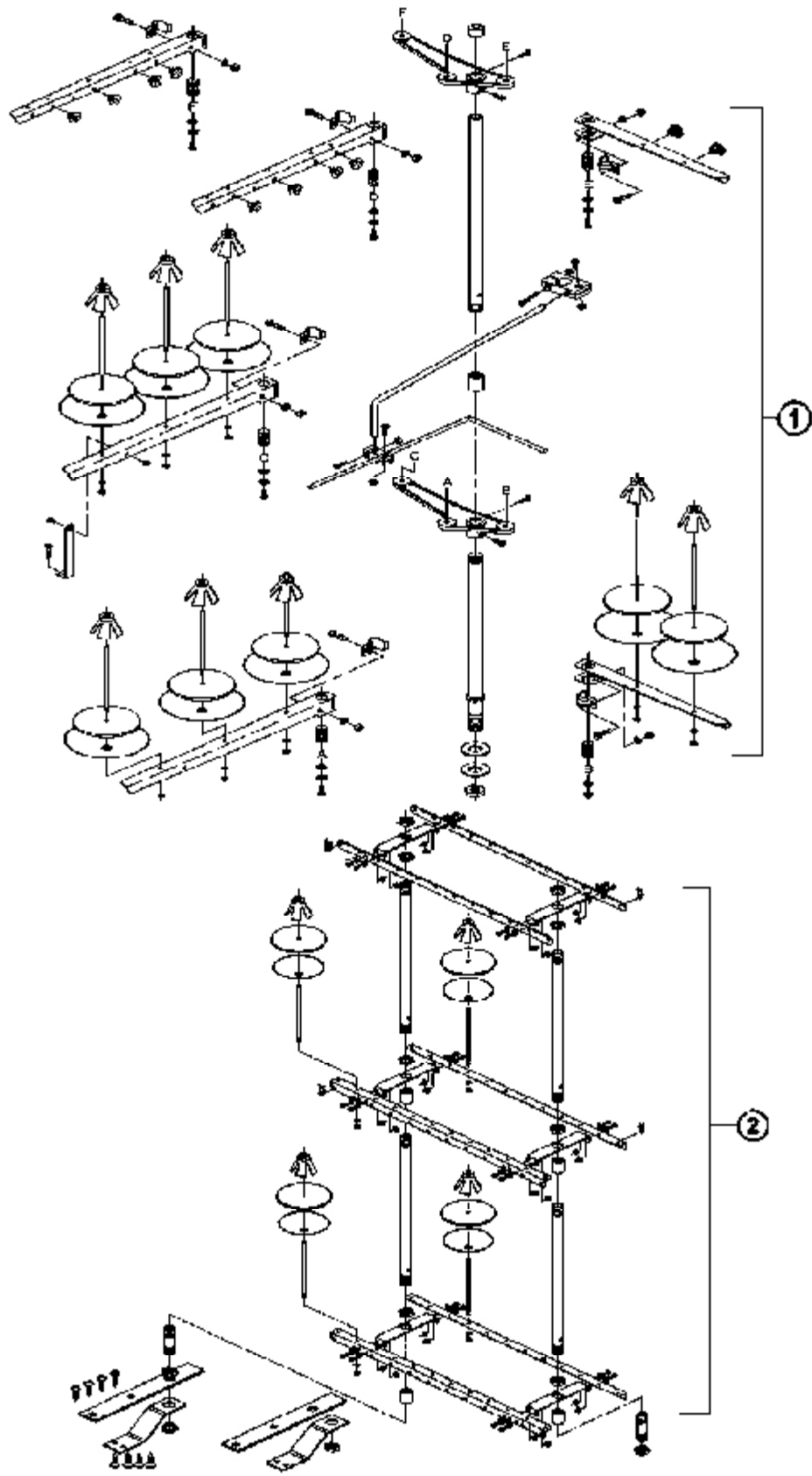

十五、附件部件(2) / Accessories Assemblies

序號 NO.	件號 Part NO.	參考件號 Ref.Part.NO.	名 稱	Description	數 量 (Number)				
					4針64	6針64	8針64	12針64	13針64
1	30532002	--- --- ---	綫架	Fight	1套	1套	1套	1套	1套
2	30532005	--- --- ---	綫架	Fight	1套	1套	1套	1套	1套

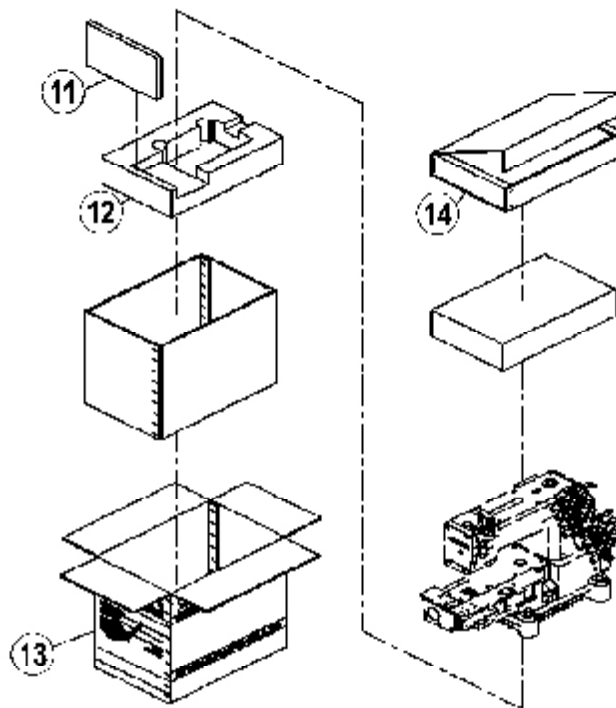
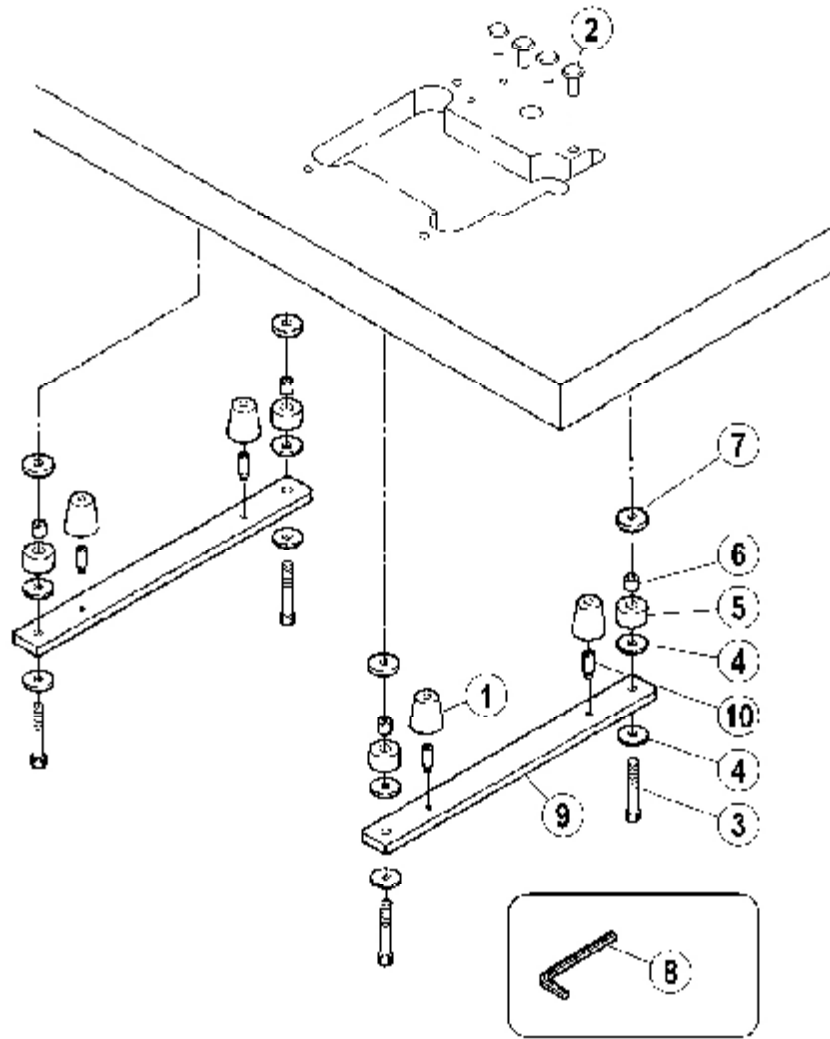

十六、附件部件(3) / Accessories Assemblies

序號 NO.	件號 Part NO.	參考件號 Ref.Part.NO.	名 稱	Description	數 量 (Number)				
					4吋 64	6吋 64	8吋 64	12吋 64	13吋 64
1	30122029	206338	油盤減振墊	Rubber cushion	4	4	4	4	4
2	301S16008	206336	托盤固定螺母	Nut	4	4	4	4	4
3	301S30017	4512	托板內六角螺釘	Bolt	4	4	4	4	4
4	20131029	KX08	金屬墊圈	Washer	8	8	8	8	8
5	20131030	KX09	托板減振墊	Rubber cushion	4	4	4	4	4
6	30103078	--- --- ---	減振墊支撐套	Spacer	4	4	4	4	4
7	30122031	--- --- ---	減震墊圈	Rubber cushion	4	4	4	4	4
8	20131045		JK795-1910內六角扳手	Spanner	1付	1付	1付	1付	1付
9	30532001	VN01	JK8008安裝板	Rest board	2	2	2	2	2
10	301S30018	--- --- ---	螺釘	Screw	4	4	4	4	4
11	30511008	--- --- ---	泡沫箱 (上)	Box	1	1	1	1	1
12	30531025	--- --- ---	泡沫箱 (下)	Box	1	1	1	1	1
13	30531026	--- --- ---	紙箱	Paper Box	1	1	1	1	1
14	30531027	--- --- ---	附件盒	Accessory Box	1	1	1	1	1

TABLE CUT-OUT OF CLINDER BED JK-8008VC-T2

單位:mm
所有尺寸公差:±2

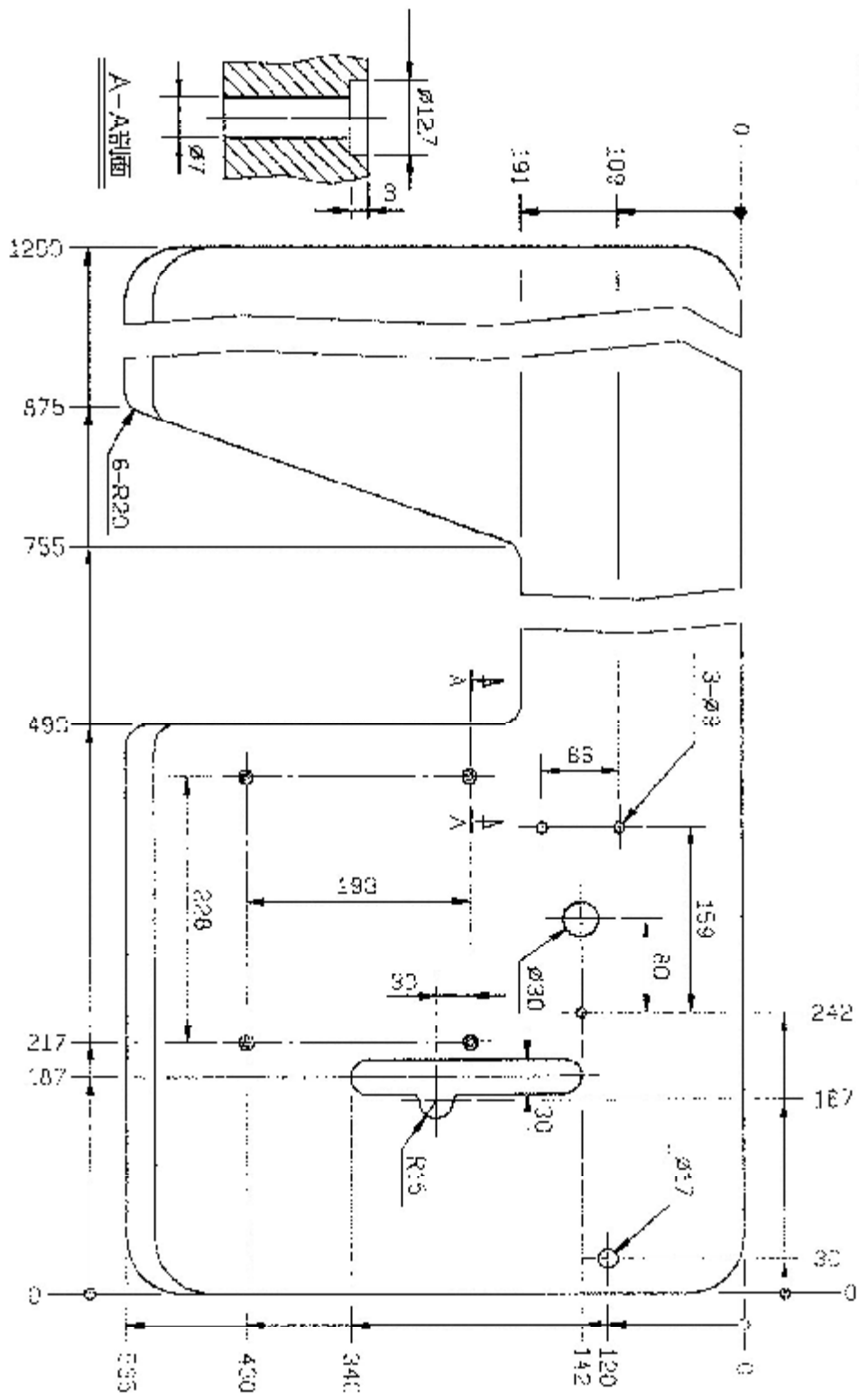

多針筒車規格件表 CONVERSION CHART









 機型 MODEL	 規格 SYB CLASS 種類 NEEDLE HOLDER		 針夾頭 NEEDLE HOLDER	 針板 NEEDLE PLATE	 牙齒 FEED DOG	 壓脚 PRESSER FOOT	 喂針軸 PETAHER HOLDER	 彎針架 LOOPER HOLDER	 針規格 NEEDLE
	規格 SYB CLASS	種類 NEEDLE HOLDER	針夾頭 NEEDLE HOLDER	針板 NEEDLE PLATE	牙齒 FEED DOG	壓脚 PRESSER FOOT	喂針軸 PETAHER HOLDER	彎針架 LOOPER HOLDER	針規格 NEEDLE
JK-8008VC-040	64F	1/4	30534709	30515509	30514309	30516009	30502834	30504029	U:113 #11-#18
	88F	:	30534301	30515501	30514301	30516001	30502838	30504003	U:113 #11-#18
	88P	1-1/8	30534310	30515510	30514310	30516010	30502832	30504021	U:113 #11-#18
JK-8008VC-060	48P	3/16	30534312	30515512	30514312	30516012	30502831	30504023	U:113 #11-#18
	64F	1/4	30534303	30515503	30514303	30516003	30502834	30504013	U:113 #11-#18
	80F	5/16	30534311	30515511	30514311	30516011	30502830	30504003	U:113 #11-#18
JK-8008VC-080	64F	1/4	30534304	30515504	30514304	30516004	30502835	30504017	U:113 #11-#18
JK-8008VC-120	48P	3/16	30534310	30515510	30514310	30516010	30502835	30504028	U:113 #11-#18
	64F	1/4	30534302	30515502	30514302	30516002	30502830	30504003	U:113 #11-#18
	64P/WT	1/4	30534302	30515502	30514302	30516002	30502839	30504003	U:113 #11-#18
	64P/WT	1/4	30534302	30515502	30514302	30516002	30502839	30504003	U:113 #11-#18
JK-8008VC-130	64-88P	1/4-1/8	30534303	30515503	30514303	30516003	30502826	30504013	U:113 #11-#18
JK-8008VC-04	A32P	1/4-1/8	30534305	30515505	30514305	30516005	30502826	30504013	U:113 #11-#18
JK-8008VC-70	82F	1/8	30534306	30515506	30514306	30516006	30502837	30504013	U:113 #11-#18
JK-8008VC-250	22P	1/8	30534308	30515508	30514308	30516008	30502829	30504021	U:113 #11-#18

TABLE CUT-OUT OF CLINDER BED JK-8008VC-T1

